

AeroNOx 2.0™

Portable Nitric Oxide Titration & Monitoring System Operator's Manual

AeroNOx 2.0™

Portable Nitric Oxide Titration & Monitoring System

Operator's Manual

- **Phone:** (512) 873-0033
- **Fax:** (512) 873-9090
- **E-Mail:** sales@int-bio.com
- **Website:** <http://www.int-bio.com>

- **Mailing address:**

**International Biomedical
8206 Cross Park Dr.
Austin, TX 78754
USA**

TABLE OF CONTENTS

1. GENERAL INFORMATION	3
1.1. Introduction	3
1.2. Intended Use.....	3
1.3. Medical Indication	3
1.4. Contraindication	3
1.5. Safety Summary	4
1.6. Classification.....	4
1.7. Important Safety Considerations.....	4
1.8. Symbols	10
1.9. Abbreviations	12
1.10. Regulators	13
1.11. Unpacking	14
1.12. Initial Setup.....	14
1.13. Purge Procedure	15
1.14. Front Panel.....	16
1.15. Rear Panel	17
1.16. Navigating Display Screens.....	18
1.17. Universal Power Supply	20
1.18. Theory of Operation.....	21
1.19. Environmental Effects.....	23
2. PRE-USE CHECKOUT/ALARM VERIFICATION	25
3. PATIENT OPERATIONS	38
3.1. Before Operation.....	38
3.2. Connection to Ventilator Circuit (General).....	38
3.3. INostat Bagger backup NO Delivery System.....	38
3.4. INostat Kit Pre-Use Checkout	39
3.5. INostat Kit Instructions for Use.....	42
3.6. Connection to Various Breathing Systems.....	43
3.7. Connection Diagram - ICU Ventilator Circuit.....	44
3.8. Connection Diagram - Transport Ventilator Circuit.....	46
3.9. Connection Diagram - High Frequency TXP-2D Phasitron	48
3.10. Connection Diagram - AeroNOx 2.0™ Bagger.....	49
4. ALARMS	50
4.1. General Alarm Information	50
4.2. Priority Alarms.....	50
4.3. Alarm Silencing	50
4.4. User Adjustable Monitor Alarms.....	51
4.5. Safety Shut Off.....	52
4.6. Alarm Table.....	53
5. CALCULATIONS & TROUBLESHOOTING	55
5.1. Calculations for Nitric Oxide Delivery.....	55
5.2. Gas Supply	58
5.3. Troubleshooting Guide.....	59
6. CALIBRATION	66
6.1. Low Range (ZERO) Calibration (Daily).....	66
6.2. O ₂ High Range Calibration (WEEKLY).....	67
6.3. NO High Range Calibration (WEEKLY)	69
6.4. NO ₂ High Range Calibration (WEEKLY).....	71
7. MAINTENANCE	74
7.1. User Maintenance Schedule	74

TABLE OF CONTENTS

7.2.	Cleaning the AeroNOx 2.0™	74
7.3.	Preventive Maintenance	75
7.4.	Return Merchandise Authorization	75
7.5.	Replacing NO, NO ₂ , and O ₂ Sensors	76
7.6.	Battery Replacement	79
7.7.	Replacing the Seal on the AeroNOx 2.0™ Regulators	80
7.8.	Parts and Accessories	81
7.9.	Mounting Options	81
7.10.	Disposal	82
8.	WARRANTY	83
9.	PRODUCT SPECIFICATIONS	85
9.1.	Ventilator Compatibility	85
9.2.	Measurement Range and Accuracy	85
9.3.	Backup Delivery Regulator	85
9.4.	INostat Bagger	85
9.5.	AeroNOx 2.0™ Delivery Regulator	86
9.6.	AeroNOx 2.0™ Physical Specifications	86
9.7.	AeroNOx 2.0™ Environmental Specifications	86
9.8.	AeroNOx 2.0™ Electrical Specifications	87
9.9.	Sensor Specifications	87
9.10.	EMC Compliance	87
9.11.	Essential Performance	90
10.	APPENDIX	91
10.1.	NO ₂ Sensor Datasheet	91
10.2.	NO Sensor Datasheet	93
10.3.	Oxygen Sensor Datasheet	95
10.4.	Competency Based Performance Check-off Tool	96

1. **GENERAL INFORMATION**

1.1. Introduction

This manual describes the theory of operation, frequently used features, safety considerations, specifications, and maintenance for the AeroNOx 2.0™ nitric oxide (NO) delivery system. Each AeroNOx 2.0™ provides the basic equipment required for NO delivery and accessories are available to accommodate specific installations.

The AeroNOx 2.0™ system includes an integrated nitric oxide gas delivery system and nitric oxide (NO), nitrogen dioxide (NO₂), and oxygen (O₂) analyzer. The AeroNOx 2.0™ is a stand-alone, lightweight, portable unit designed to continuously monitor NO, NO₂, and O₂ concentrations in a breathing circuit.

The AeroNOx 2.0™ system is specifically designed for the delivery and monitoring of gaseous nitric oxide (NO) in parts per million (ppm) concentrations.

The AeroNOx 2.0™ is designed for use within a hospital or during patient transfer via rescue vehicle, fixed wing aircraft, or helicopter.

1.2. Intended Use

The AeroNOx 2.0™ is intended to provide a constant controlled concentration of nitric oxide in breathing gas by delivering a constant controlled flow of nitric oxide into the inspiratory limb of a mechanical ventilator that operates using a continuous constant flow of fresh gas into the inspiratory limb of the ventilator. The AeroNOx 2.0™ is also intended to be used with a flow inflating manual ventilator (an AeroNOx 2.0™ accessory), by introducing controlled flows of nitric oxide into the fresh gas flow to the manual ventilator. It is also intended to monitor nitric oxide, nitrogen dioxide, and oxygen concentrations in the breathing gas.

The AeroNOx 2.0™ is intended to be used within a hospital or during air or ground transport outside the hospital.

1.3. Medical Indication

Nitric oxide therapy is intended to treat late pre-term neonates (≥ 34 weeks gestation, < 14 days of age) diagnosed with Persistent Pulmonary Hypertension of the Newborn (PPHN) described as:

- a. A failure to achieve transition to air breathing due to a lung parenchymal disease such as meconium aspiration syndrome, pneumonia, or infant respiratory distress
- b. Idiopathic PPHN in which the lung parenchyma is normal but the pulmonary vasculature has been remodeled
- c. Documentation of pulmonary hypertension by a pediatric cardiologist

1.4. Contraindication

The only contraindication for inhaled nitric oxide therapy is neonates dependent on right-to-left shunting of blood. Always refer to the inhaled Nitric Oxide Gas prescribing information sheet.

1.5. Safety Summary

The AeroNOx 2.0™ is intended for use only by qualified clinicians, under the direction of a qualified physician. All personnel operating the system should be thoroughly familiar with operating instructions, warnings, and cautions contained in this manual. The AeroNOx 2.0™ should be verified according to the procedures in this manual before putting into operation. If the unit fails any portion of the checkout procedure, it must be removed from service and repaired.

1.6. Classification

According to the standard EN60601-1 of the International Electrotechnical Commission, *Medical electrical equipment, Part 1: General requirements for safety*, the AeroNOx 2.0™ is classified as follows:

- Class II / Internally Powered, according to the type of protection against electric shock
- IP33, according to the degree of protection against harmful ingress of water and solid objects
- Continuous operation for the mode of operation

1.7. Important Safety Considerations

Safety concerns or additional pertinent information will be displayed using warnings, cautions, and notes, having the following significance:

▲ WARNING

Alerts to potential serious injury, adverse event, or safety hazard.

▲ CAUTION

Alerts to the possibility of minor injury or damage to the equipment.

NOTES:

Provides additional information to clarify a point in the manual.

The principal **WARNING** and **CAUTION** notices to be observed in use of this device are brought together here for emphasis.

▲ WARNING

Use of the AeroNOx 2.0™ is contraindicated for patients with congenital heart disease on right-to-left shunt, congenital anomalies, or congestive heart failure.

Do not use the AeroNOx 2.0™ in oxygen rich environments.

If an alarm occurs, safeguard patient before troubleshooting or repair procedures.

Use only pharmaceutical grade NO.

The AeroNOx 2.0™ must be used in accordance with indications, usage, contraindications, warnings, and cautions described in this manual.

The use of devices which radiate high intensity electrical fields may affect the operation of the AeroNOx 2.0™. Constant assessment of the patient and all life support equipment is mandatory whenever interfering devices are operating on or near patient.

When using the AeroNOx 2.0™ adjacent to or stacked with other equipment, observe the operation of the AeroNOx 2.0™ and the other equipment to ensure normal operation.

Portable RF communications equipment (including peripherals such as antenna cables and external antennas) should be used no closer than 30 cm to any part of the AeroNOx 2.0™ and associated cables. Otherwise, degradation of the performance of this equipment could occur.

Do not use the AeroNOx 2.0™ with helium/oxygen mixtures. The AeroNOx 2.0™ is only intended to deliver NO in conjunction with oxygen/air mixtures.

Anytime a new NO gas cylinder and regulator is used, the user must purge to prevent inadvertent delivery of NO₂ to the patient.

If the AeroNOx 2.0™ is not going to be used within 10 minutes, depressurize the regulator supply line.

If the AeroNOx 2.0™ is pressurized and not used within 10 minutes, repeat the purge procedure.

If the AeroNOx 2.0™ is not depressurized and not used within 12 hours, repeat the pre-use procedure.

A backup NO delivery system must always be available in the event the primary system should fail.

Set AeroNOx 2.0™ alarm thresholds for the current patient conditions to monitor any inadvertent changes in treatment. For alarm information, see Section 4., ALARMS.

Be certain all lines and cables are organized to prevent damage or occlusion.

Use only parts, accessories, transducers, and cables designated by International Biomedical for use with the AeroNOx 2.0™. Cables and accessories other than those supplied by International Biomedical may result in unacceptable operation of the AeroNOx 2.0™ and will void the equipment warranty.

The AeroNOx 2.0™ samples gas at a rate of 220 mL/min; this can affect the sensitivity of flow triggered synchronized breath of some ventilators. The trigger sensitivity, if equipped, should be checked after connecting AeroNOx 2.0™ to the breathing circuit.

Do not change NO, NO₂, or O₂ sensors while in use.

Do not attempt to maintain, diagnose, or repair the AeroNOx 2.0™ while delivering NO to a patient.

No modification of the AeroNOx 2.0™ is allowed.

Improper sensor or battery replacement will result in a non-functional or inaccurate device.

Sample/Delivery accessories are single patient use only. DO NOT re-use.

Improper maintenance or replacement of sensors may pose a safety risk to the patient. Maintenance should be performed by qualified service personnel per the instructions.

Perform cylinder connection and purge procedures in well-ventilated areas to prevent inadvertent exposure to nitric oxide or nitrogen dioxide gas. Follow your facility's safety procedures for handling medical gas cylinders.

Overexposure to NO or NO₂ can lead to physiological effects such as hypoxia which are not apparent to the operator.

The IP33 rating applies when the AeroNOx 2.0™ is on battery power with the DC Input jack properly sealed.



Caution: U. S. Federal and Canadian law restricts this device to sale by or on the order of a physician or other licensed medical practitioner. Outside Canada and the U. S., check with local laws for applicable restrictions.

When using the AeroNOx 2.0™ Bagger or INOstat Bagger, oxygen and NO mix in the reservoir bag. If not actively bagging patient, turn NO flow off to prevent formation of NO₂. Flush the bagger for 20 seconds before and after use to completely remove NO and NO₂.

Concentrations of NO₂ in the reservoir bag may exceed 1 ppm. Large tidal volumes may expose patients to NO₂ in the reservoir bag. If any interruption occurs during patient bagging, system should be flushed for 20 seconds.

When using the AeroNOx 2.0™ Bagger or INOstat Bagger, short duration, rapid fluctuations in delivered gas concentration including NO₂ is possible. Therefore, the AeroNOx 2.0™ Bagger and INOstat Bagger are designed for short term use only.

Do not use AeroNOx 2.0™ Bagger or INOstat Bagger to deliver concentration in excess of 20 ppm. The generation of NO₂ increases rapidly above this concentration.

Do not alter the length of the INOstat Bagger gas supply tubing as this may cause generation of excessive levels of NO₂.

Do not substitute AeroNOx 2.0™ Bagger or INOstat Bagger components. The Bagger Systems have been designed and tested for patient safety with the components included.

The AeroNOx 2.0™ Bagger and INOstat Bagger are intended to connect directly to the patient's endotracheal tube. Do not insert any additional tubing between the Bagger and the endotracheal tube.

The AeroNOx 2.0™ Bagger and INOstat Bagger are single patient use. Do not reprocess.

The INOstat Kit is intended for use if the primary NO delivery device (AeroNOx 2.0™) fails. The INOstat Kit is not intended as a primary NO delivery device.

The back-up delivery regulator in the INOstat Kit is preset with a 0.25 L/min flow. It is intended to be used only with the INOstat Bagger. Do not use this regulator for any other application.

Persons using the AeroNOx 2.0™ should be trained and experienced in the use of this device to assure effective administration of NO, and to avoid injury to the patient or to others resulting from inhalation of excess NO, NO₂, or other reaction products. Not for use by patients.

Persons using this device who may be particularly sensitive to nitric oxide or nitrogen dioxide, or who may be exposed to these gases for prolonged periods as a result of the use of this device, should be aware that the AeroNOx 2.0™ does not scavenge the exhaust gas, and that this gas is vented from the underside of the AeroNOx 2.0™, or through the side vent in the event that the bottom port is occluded. Ambient concentrations of nitric oxide or nitrogen dioxide expected to result from the use of this device are less than 50 ppb.

Only use International Biomedical approved batteries for AeroNOx 2.0™.

Even when the external power supply is not connected, the battery provides a bias charge to the NO, NO₂, and O₂ cells to keep sensors in a ready state. The power drawn from biasing the sensors will deplete a new fully charged battery in approximately one week. Because of this, it is recommended the external power supply of the AeroNOx 2.0™ remain plugged in at all times to maintain battery charge.

Disconnect the battery or leave charging when not in use for extended periods of time.

Allowing the battery to fully discharge repeatedly will reduce the overall number of cycles in the life of the battery.

Attempting to run the AeroNOx 2.0™ for longer than five hours on battery only could result in an interruption of nitric oxide therapy.

The specified power supply is defined as part of the ME Equipment. Use only the International Biomedical approved universal power supply for AeroNOx 2.0™.

No other devices are known to cause potential interference with the AeroNOx 2.0™. If interference occurs, discontinue use of the AeroNOx 2.0™ and use the INOstat Bagger.

Never turn on the NO delivery gas without first turning on the ventilator or bagger flow. Failure to do this will result in undiluted gas delivery entering the sampling chamber and exposing the sensors to levels of NO and /or NO₂ which may damage the sensors.

NO₂ gas may have collected in the AeroNOx 2.0™ delivery or ventilator circuit during setup. Run ventilator and AeroNOx 2.0™ on a test lung 30 seconds prior to patient connection to ensure analyzed levels of NO₂ and NO are appropriate.

Only use the NO Worries Sample line with filter and Nafion® tubing when operating the AeroNOx 2.0™. Failure to do so may result in the egress of moisture which can impair function as well as damage internal components.

NO flow must be continually evaluated during nitric oxide administration to ensure accurate dosing.

NO cannot be administered during the calibration process.

Do not sterilize or disinfect with power connected.

Allow unit to dry thoroughly before use. Immediate use after exposure to excessive cleaning agents such as Isopropyl Alcohol can affect sensor performance.

Do not push on LCD display.

The VESA 75 mount is required for mounting during transport.

Should there be a sudden need to change therapy tanks; a second tank should always be purged and ready for immediate use. Perform the purge procedure immediately upon installation of a new regulator.

The flush procedure must be performed each time NO therapy is started. This includes initial therapy starts, tank changes, and re-starting therapy after NO has been off.

Powering the unit off will shut off the delivery gas flow. Gas flow is terminated when the unit is powered off, whether intentionally, or during a complete loss of power.

DO NOT exceed 2.00 LPM as displayed on the AeroNOx 2.0™ flow display. Displayed values in excess of 2.00 LPM are not accurate. If the flow on the AeroNOx 2.0™ flow meter is set at a value greater than 2.00 LPM, the delivered flow will be higher than the displayed flow value.

The NO₂ sensor may easily be damaged by inadvertent high levels of NO₂. Use Nitrogen or air to flush the system after high levels of NO (> 100 ppm) or NO₂ (> 20 ppm) have been introduced to the sensor.

Setting alarm limits to extreme values can render the alarm system useless.

After storage at the extremes of the allowable temperature range, it is recommended that the AeroNOx 2.0™ be given at least an hour at room temperature before use.

NOTES:

The Low Cal does not require calibration gases.

Connections to various ventilators are unique to each manufacturer as well as their corresponding disposable circuits.

When AeroNOx 2.0™ is connected to a ventilator and patient is breathing spontaneously, a slight change in NO ppm (< 10%) may be noted.

When performing high range calibration, make sure to select the correct calibration gas and confirm expiration date before using.

Never connect calibration circuit to a pressure source > 50 cm H₂O; this could damage the sampling system.

Protective cover not shown in many images throughout this manual should be used at all times to provide extra impact resistance if dropped.

AeroNOx 2.0™ is shipped with battery uninstalled. Follow installation procedure in Section 7.



















Do not mount or position the AeroNOx 2.0™ such that the rear power connection, exhaust ports, or the NO inlet are blocked.

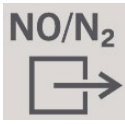
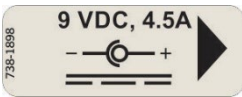
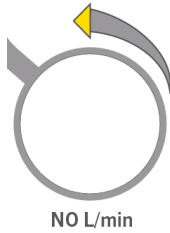
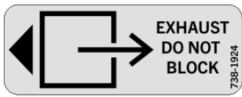



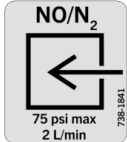
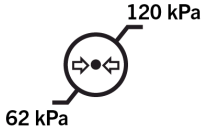
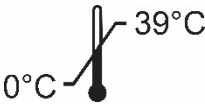











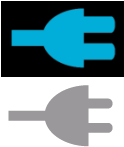

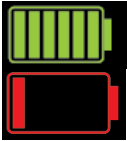
The recommended storage temperature limits are within operational temperature limits to preserve sensor life. No specific time to cool or warm from storage temperature extremes is indicated. Before normal use, a pre-check must be performed to allow sensors to stabilize.

Use the tethered rubber plug to seal the DC input jack from the environment when not in use.

1.8. Symbols

The following symbols appear in the AeroNOx 2.0™ documentation and labels.

	“ON”/“OFF” Power (Hold for ~3 Seconds to turn off)		Soft Key (3)
	Silence Alarm Button		Date of Manufacture
	Dim Backlight Button		Manufacturer contact information
	Back Button		General Warning, Caution, Risk of Danger
	NO Sample Inlet		Do not discard in trash
	NO/N ₂ Delivery Outlet		Use indicated power supply only
	Nitric Oxide Flow Control (Increasing flow counter clockwise)		Exhaust Do Not Block
	ATTENTION: Observe precautions for handling electrostatic sensitive devices.		Use only the specified replacement battery.
	Consult Instructions For Use		NO/N ₂ Supply Gas Input
	Operating pressure limits		Operating temperature limits
	Type BF Applied Part		Class II Equipment
	Device serial number		Prescription use only

	Device part number		Decrease Value
	Confirmation		Set Low Alarm Limit
	Select High/Low Alarm Limits		Set High Alarm Limit
	Increase Value		AC Power Plugged in and Charging
	Alarm Temporarily Silenced for Approximately 60 Seconds		Screen Lock
	Battery Level Full / Low		Screen Unlock (Hold to unlock)
	Hold Button Timer (Moving Pie Chart)		Lock Prohibited with unacknowledged alarm
	Nitric Oxide Concentration in Parts Per Million		Percent Oxygen
	Nitrogen Dioxide Concentration in Parts Per Million		Zero Calibration Screen Soft Key
	Set NO=0, NO ₂ =0, and %O ₂ =21 Soft Key (Hold to zero)		High Calibration Screen Soft Key

1.9. Abbreviations

ABBREVIATION	DEFINITION
AC	Alternating Current
CISPR	International Special Committee on Radio Interference
cm	Centimeters
DC	Direct Current
ESD	Electrostatic Discharge
FiO ₂	Fraction of Inspired Oxygen
FSO	Full Scale Output
ft.	Feet
HFOV	High Frequency Oscillatory Ventilation
IB	International Biomedical
in	Inches
L/min	Liters per Minute
mA	Milliamps
mbar	Millibars
mL/min	Milliliters per Minute
mm	Millimeters
mmHg	Millimeters of Mercury
N ₂	Nitrogen Gas
NO	Nitric Oxide Gas
NO ₂	Nitrogen Dioxide Gas
O ₂	Oxygen Gas
PM	Preventative Maintenance
ppb	Parts per Billion
ppm	Parts per Million
psi	Pounds per Square Inch
psig	Pounds per Square Inch Gauge
PTFE	Polytetrafluoroethylene
RH	Relative Humidity
RF	Radio Frequency
V	Volts
VESA	Video Electronics Standards Association

1.10. Regulators

Delivery, calibration, and backup regulators are supplied with gauges displaying pressure in psig. The sealing tips are a wear item that require replacement periodically or if damaged. Note these tips are specific to the bottle connection type and must be replaced accordingly as shown in the table below. Section 7., MAINTENANCE contains more information on replacement tips.

<p>Delivery (CGA 626)</p>		<p>731-9142</p>
<p>Calibration (CGA 625)</p>		<p>731-9141</p>
<p>Backup (CGA 626)</p>		<p>731-9143</p>
<p>Replacement Parts</p>	<p>Seal O-Ring (CGA 625/626)</p> <p>Seal Nipple (CGA 626)</p> <p>Seal Nipple (CGA 625)</p>	<p>731-0644</p> <p>731-9374</p> <p>731-9375</p>

1.11. Unpacking

Verify that the shipping carton contains the following equipment.

Component	Part Number	Quantity
AeroNOx 2.0™	731-0426	1
AeroNOx 2.0™ NO supply Hose, 6'	738-1862	1
Battery Assembly (SLA or LiFePO ₄)	888-0115 or 888-0013	1
AeroNOx 2.0™ Multilanguage Documentation CD	717-0004	1
AeroNOx 2.0™ Operator's Manual	715-0086	1
Delivery Regulator with CGA 626 Fitting	731-9142	2
Power Supply Assembly, 9V, Locking, AeroNOx 2.0™	738-1964	1
Power Cord, NEMA 1-15P to IEC60320 C7, 6ft	738-1916	1
AeroNOx 2.0™ Service Manual	715-0088	1
AeroNOx 2.0™ Sample/Delivery Kit	738-1853	1
AeroNOx 2.0™ TXP HFV Sample/Delivery Kit	738-1854	1
AeroNOx 2.0™ Test Circuit	738-1889	1
AeroNOx 2.0™ Calibration Circuit*	738-1850	1
AeroNOx 2.0™ Transport Mount, Adapter Block	731-0330	1
Power Cord, CEE 7/16 to C7, 2m, AeroNOx 2.0™	738-1963	1

*Calibration requires a calibration regulator. An INOstat Backup Bagger kit is also required in the event of AeroNOx 2.0™ failure during use. If your hospital does not have each of these, they must be purchased as separate items shown below. The same regulator may be used for NO and NO₂, but a purge procedure must be completed each time it is attached to a new bottle of gas.

Component	Part Number	Quantity
Calibration Regulator with CGA 625 Fitting	731-9141	1
INOstat Kit	731-9147	1

1.12. Initial Setup

- a. Unpack the AeroNOx 2.0™ and inspect for damage.
- b. Install battery as per Section 7., MAINTENANCE, "Battery Replacement". The AeroNOx 2.0™ was shipped with an uninstalled battery for safety. The SLA and LiFePO₄ batteries are not interchangeable.
- c. Unpack 9 VDC power supply (P/N 738-1964) and Power Cord (P/N 738-1916 or 738-1963). Plug in AeroNOx 2.0™ and charge for 48-72 hrs.
- d. Calibrate the AeroNOx 2.0™. (See Section 6., CALIBRATION.)
- e. Perform Section 2., PRE-USE CHECKOUT/ALARM VERIFICATION, before administering therapy to a patient.
- f. Install AeroNOx 2.0™ per the appropriate situation described in Section 3., PATIENT OPERATIONS.

1.13. Purge Procedure

Please follow purge instructions below to ensure gas purity. Failure to follow these instructions may introduce potentially harmful contaminants into the patient's breathing gas or may affect the monitoring analyzer's accuracy by introduction of contaminants into the calibration gas.

Any time a regulator is installed on a tank or cylinder of compressed gas, certain precautions must be followed. This is to prevent contamination of the gas in the tank and in the system by air that is trapped in the dead space of the regulator, hose, and fittings. To eliminate the possibility of the oxygen in this air reacting with the nitric oxide to form nitrogen dioxide in the system, the regulator, hose, and fittings must be purged before use. The valve on the tank must not be opened and left open until the regulator is purged. The stainless steel hose must also be purged prior to connection to the AeroNOx 2.0™.

1.13.1. **Purge Procedures for use with Medical Gas Regulators:**

- a. Connect cylinder to a matching CGA 626 nitric oxide or nitrogen dioxide regulator only.
- b. Connect stainless steel hose to quick disconnect.
- c. Open, then immediately close the cylinder valve pressurizing the hose.
- d. Purge (bleed) all of the gas from the regulator and hose with the purge pin on the AeroNOx 2.0™.
- e. Repeat steps c. and d. four more times for a total of five purge cycles.
- f. Leave the regulator installed until it is time to change to a new cylinder.
- g. Repeat the purge procedure any time a regulator is reattached.

Although the dead space volume in the regulator and hose assembly is physically small, if it had been exposed to room air for a period of time it will contain sufficient oxygen to convert a significant amount of nitric oxide to nitrogen dioxide.

1.14. Front Panel



1	Sample Line Inlet	Sample Line Filter Plugs Into Quick Disconnect
2	Delivery Line Outlet	Delivery Line Fitting
3	NO Flow Control	Sets NO Flow to Delivery Outlet
4	Power	Turns Power On/Off
5	Main Screen	Displays Measured and Alarm Parameters
6	Alarm Silence Key	Silences Alarm For One Minute
7	Backlight	Dims Backlight to 50% Normal
8	Back	Returns to previous screen
9	Soft Keys	Variable Function Keys Correspond to Screen Menu
10	Charging Indicator	Green LED illuminates when plugged-in
11	Protective Cover	Removable impact protection

1.15. Rear Panel



1	NO/N ₂ Gas Inlet	Quick Connect for NO Gas Delivery
2	Purge Pin	Purge Pin for NO Delivery Line
3	Sensor Housing Cover	Houses NO, NO ₂ , and O ₂ Sensors
4	Sample Gas Exhaust Ports	Gas Escape for Internal Pump
5	Dovetail Mounting Bracket	Mounts AeroNOx 2.0™ on Pole or Handle
6	Battery Housing Cover	Houses 6 volt Battery
7	Power Supply LED Indicator	Indicates if Unit is Connected to A/C Power
8	Power Supply Cord Outlet	Power Supply Connection w/Dust Cover
9	VESA 75 Mount (4 × M4 Screws)	75 mm × 75 mm Mounting Pattern
10	Handle	Integrated Handle

1.16. Navigating Display Screens

There are two screens that can be displayed on the AeroNOx 2.0™ NO delivery system. Main display screen and Calibration screen.

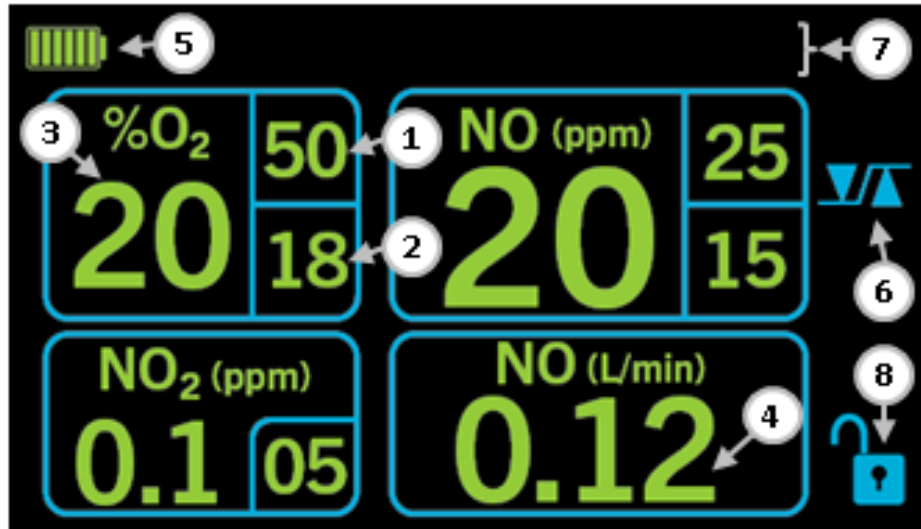

1.16.1. **Main Display Screen**

On the main screen the operator can monitor values and alarm messages.

1	Upper Alarm Limit
2	Lower Alarm Limit
3	Measured Value
4	NO Flow Rate Display
5	Battery Life or A/C Power
6	Alarm Settings
7	Message Area
8	Screen Lock Status

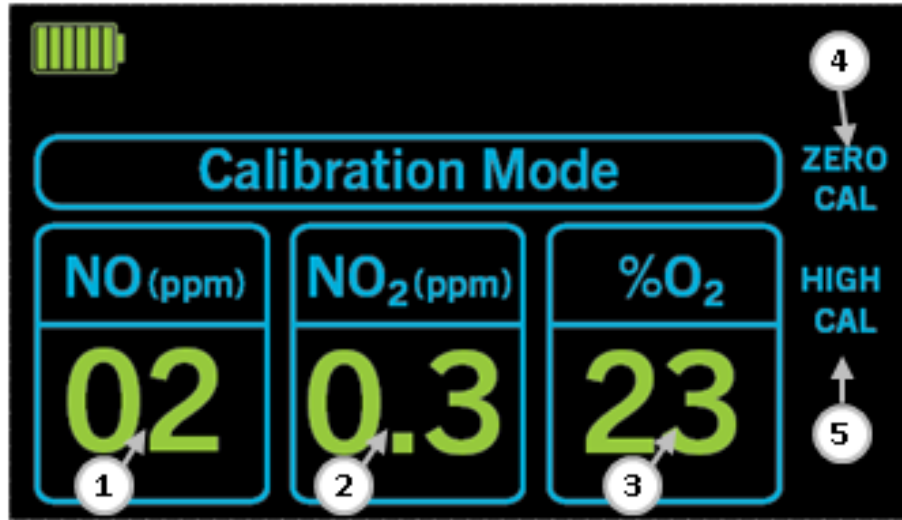







1.16.2. Calibration Mode Display Screen

During the first five seconds of start-up, user has the option of entering the calibration display screen. The calibration screen lets the user select different calibration options which will be covered in Section 6.

1	NO Measured Value
2	NO ₂ Measured Value
3	O ₂ Measured Value
4	Room Air Calibration (Zero)
5	NO, NO ₂ , O ₂ Calibration with Known Calibrated Gas

1.17. Universal Power Supply

Description	Illustration
<p>The universal power supply is both a voltage source for internal charging and an AC power supply.</p> <p>The internal charging circuit will sense battery type and condition and adjust the charge as necessary.</p> <p>Even when the external power supply is not connected, the battery provides a bias charge to the NO, NO₂, and O₂ cells to keep sensors in a ready state. The power drawn from biasing the sensors will deplete a new fully charged battery in approximately one week. Because of this, it is recommended the external power supply of the AeroNOx 2.0™ remain plugged in at all times to maintain battery charge.</p> <p>Connect power supply to AeroNOx 2.0™ by inserting power plug into the DC jack on the back side and screwing the locking ring onto the jack. A green LED light on the back and the front indicates that the power is supplied to the AeroNOx 2.0™.</p> <p>The power supply is a non-ME Equipment element of the AeroNOx 2.0™ ME System. The power supply has an IP rating of IP22. When not connected, use the tethered rubber plug to seal the DC input jack from the environment to maintain the IP33 rating of the ME Equipment.</p>	  
<p>A low battery alarm will alert the user when there are approximately 15 minutes remaining. (See Section 4., ALARMS.)</p>	

POWER STATES						
Power State	LCD DISPLAY	External Supply	LCD Indicator	Green LED Lights	Battery Status	Life
 OFF	OFF	PLUGGED-IN	OFF	ON	CHARGING	INDEFINITE
 OFF	OFF	UNPLUGGED	OFF	OFF	MAINTAINING SENSOR BIAS	~1 WEEK
 ON	ON	PLUGGED-IN		ON	CHARGING	INDEFINITE
 ON	ON	UNPLUGGED		OFF	SYSTEM RUNNING	~5 HOURS
 ON	???	PLUGGED-IN	???	ON	NOT INSTALLED!	INVALID! INSTALL BATTERY

1.18. Theory of Operation

The AeroNOx 2.0™ NO delivery system provides a constant dose of NO gas into the inspiratory limb of the ventilator circuit. The AeroNOx 2.0™ utilizes a bi-logic design to ensure safe delivery of NO to the patient. First, a NO delivery logic system precisely measures flow of NO to the ventilator circuit to maintain an accurate NO level. Second, a separate gas monitoring system uses NO, NO₂, and O₂ sensors to continuously measure and display concentrations. The dual logic approach allows independent delivery of NO and monitoring. The dual logic also allows the monitoring system to shut down AeroNOx 2.0™ delivery if it detects a fault in the delivery system (See Below). The set-up delivery and monitoring is performed by a trained clinician.

1. The cylinder regulator is attached to the AeroNOx 2.0™ via stainless steel tubing to the NO/N₂ quick disconnect located on the back of the device.
2. NO gas enters the back of the AeroNOx 2.0™ then through a safety shut-off valve which is open during normal operation.
3. A delivery line is placed in the inspiratory limb of the ventilator circuit, between the outlet and humidifier (if applicable). Based on the ventilator flow, NO gas concentration, and desired dose, the operator adjusts NO flow to reach prescribed dose.

4. NO Gas Monitoring

- The AeroNOx 2.0™ displays values for NO and NO₂ in parts per million (ppm) and %O₂. A sample line is placed in the inspiratory limb of the ventilator circuit at least 30 cm (12 in) downstream of the delivery line. Sample gas is withdrawn from the breathing circuit and goes through Nafion® dryer tubing, a hydrophobic small particle filter, a sample pump, and finally through the gas monitoring sensors.
- The pump ensures a sample gas flow rate is maintained to the monitoring sensors.
- Gas monitoring sensors are electrochemical; they are specific to each gas and provide an electronic signal that when properly calibrated correlates to the concentration of the gas present.

5. The operator should face the AeroNOx 2.0™ screen, monitoring its status during normal use.

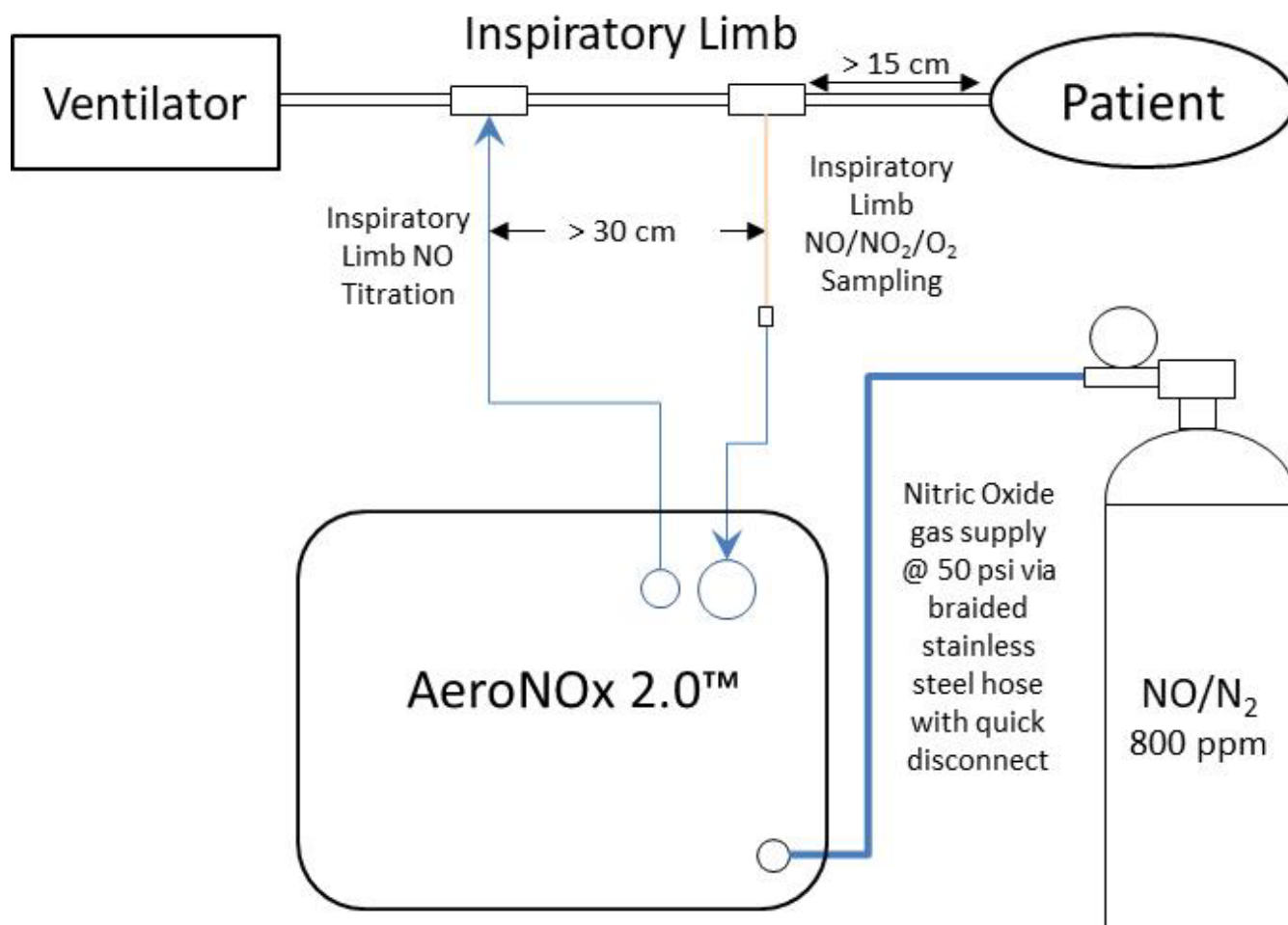

1.19. Environmental Effects

The AeroNOx 2.0™ NO, NO₂, and O₂ sensors are specified for use up to 12,000 ft., but above 10,000 ft. it is recommended that the external supply be unplugged to ensure electrical isolation. The AeroNOx 2.0™ will continue to operate on internal battery power for approximately 5 hours until it must be plugged in again to continue and recharge.

1.19.1. **NO and NO₂**

These sensors are electrochemical cells with a signal governed by gas diffusion through a membrane. Sudden pressure changes will increase the diffusion rate causing a bump in the signal for a few seconds until the pressure is equalized on both sides of the membrane. Once equalized, diffusion once again becomes the dominant effect creating a signal. Therefore the NO and NO₂ sensors have a very low pressure dependence, but are subject to sudden pressure changes. For use in the AeroNOx 2.0™ application, this is not a problem.

1.19.2. **Oxygen**

The sensor actually senses partial pressure of oxygen, not percentage. Therefore changes in barometric pressure change the reading, even if the percent of oxygen in the sample remains constant.

Partial pressure of oxygen (PO₂) equals the percent of oxygen (%O₂) times (×) the pressure at which the sample is measured (mmHg-mercury):

$$PO_2 = (\%O_2) (\text{mmHg})$$

For example:

At sea level, the pressure equals 760 mmHg and dry air contains 21% O₂. Therefore;

$$\begin{aligned} PO_2 &= (21\%) (760 \text{ mmHg}) \\ PO_2 &= 160 \text{ mmHg} \end{aligned}$$

If the instrument is calibrated to read 21% at 160 mmHg partial pressure, and the instrument is then moved to an area above sea level where the atmospheric pressure is 700 mmHg, a lower reading is found due to a lower partial pressure.

$$\begin{aligned} PO_2 &= (21\%) (700 \text{ mmHg}) \\ PO_2 &= 147 \text{ mmHg} \end{aligned}$$

The percent reading on the instrument is derived by the following formula:

$$X = \frac{(21\%)(147 \text{ mmHg})}{(160 \text{ mmHg})} = 19.3\%$$

Therefore, to eliminate error caused by pressure changes, the instrument must be calibrated at the pressure and flow rate at which it is to be used.

Source: Ohio Medical MiniOX 1A Operation Manual, P/N 806129 [Rev. 1] 09/2010

1.19.3. **Flow Meter Display**

The flow meter is based on mass flow but volumetric flow is displayed based on standard atmospheric conditions. Therefore at higher altitudes, the display will not change even though volumetric flow rate has increased.

1.19.4. **Other Environmental Conditions**

The EMS environment is an uncontrolled and changing environment that requires the operator to react to conditions not seen in a typical healthcare facility. Rapid changes in temperature, pressure, lighting, vibration, noise, power, and cleanliness must be considered. The AeroNOx 2.0™ is designed to withstand these quickly changing conditions.

- The LCD may wash out in direct bright sunlight but simply changing viewing angle will make the screen visible again. Dust and lint may be wiped using standard cleaning procedures described in this manual.
- While no known devices interfere directly with the AeroNOx 2.0™, the user must recognize signs of a problem including erratic displayed sensor values. In the event of temporary interference, the device may alarm, then recover and continue to operate normally. In other circumstances, the user must recognize a persistent problem and be ready to use the backup bagger.
- Power is generally unreliable and noisy in an EMS environment, so the AeroNOx 2.0™ internal battery automatically takes over when externally supplied power cuts out. The user should recognize the change in power status and monitor the battery level as required to ensure safe transport.

1.19.5. **Degraded Performance**



As the device ages, the sensors, battery, or pump may change characteristics.



- As the sensors near their end of life, their response to the sampled gas may decrease. The high range calibration compensates for this condition until the response is no longer high enough to be valid. At this point a calibration error will occur. If wires break loose or connections corrode, the sensors will respond erratically causing an alarm condition or calibration error.
- Despite the use of an inlet filter, the pump or sample circuit may eventually become partially clogged with contaminants or debris, reducing the sample flow rate. The gas sensors will still measure accurately, but their response time may increase due to lower flow. The yearly preventative maintenance cycle should identify any issues that need to be addressed.
- The battery may not hold a complete charge or it may not last as long as a new battery, but the device will still work on external power as long as a battery with some capacity is present. Allowing the battery to fully discharge repeatedly will reduce the overall number of cycles in the life of the battery.



Therefore, it is important that the user performs the pre-use checkout procedures in this manual to ensure the device is calibrated and functioning properly before being used on a patient. If the device cannot be calibrated properly, or if the sensors have been compromised, it must be serviced before use.



2. PRE-USE CHECKOUT/ALARM VERIFICATION

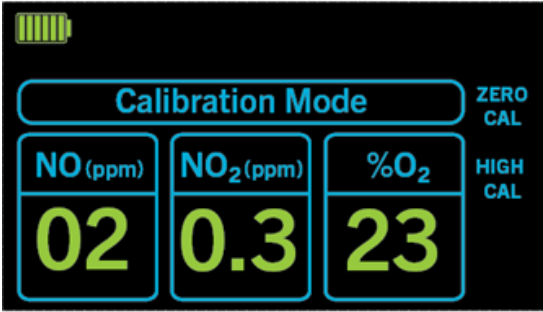
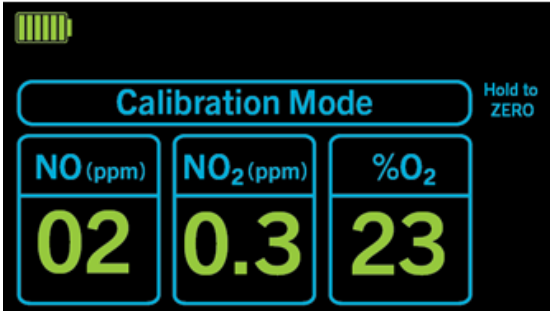
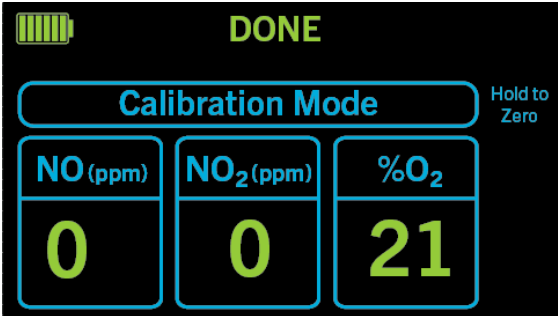

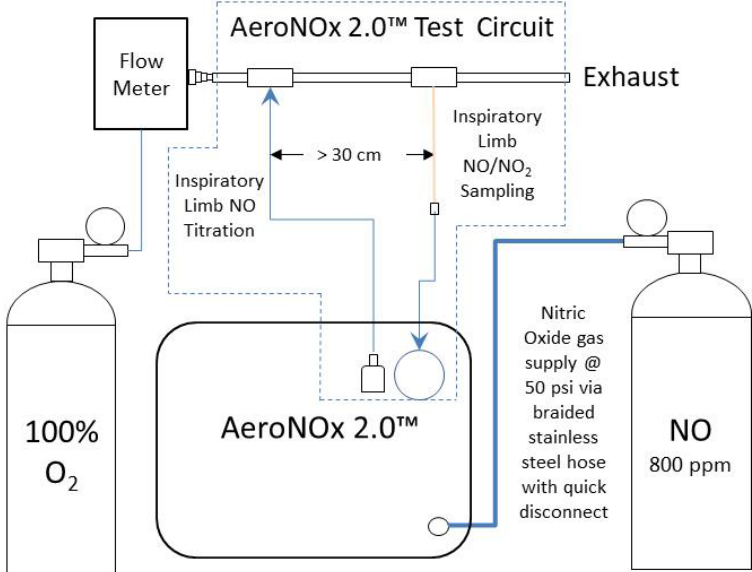

Pre-use procedures consist of the following tests which must be done before delivering NO gas to the patient. This procedure simulates a ventilator circuit with constant flow by using a 100% O₂ source and a flow meter:



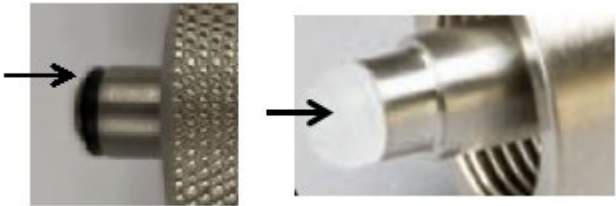

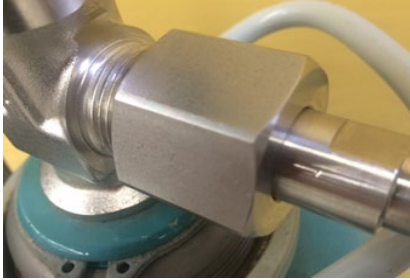
Description	Step	Illustration
Obtain AeroNOx 2.0™	1	 <p>The illustration shows the AeroNOx 2.0 device, a rectangular unit with a central screen and various ports and buttons. The screen is currently blank. The device is labeled 'AeroNOx 2.0' in the top right corner.</p>
Connect power supply to AeroNOx 2.0™. Insert power cord into receptacle on the back panel and tighten lock ring. A green LED light indicates external power is supplied to the AeroNOx 2.0™.	2	 <p>The illustration is a close-up of the power input port on the back of the device. A black power cord is inserted into the port, which is secured with a black lock ring. A green LED light is illuminated above the port. A white label next to the port specifies '9 VDC, 4.5A' and shows a polarity diagram with a '+' sign.</p>
Turn the AeroNOx 2.0™ on by pressing the "ON/OFF" button.	3	 <p>The illustration shows the front panel of the AeroNOx 2.0 device. A black arrow points to the 'ON/OFF' button, which is a small circular button located to the right of the 'NO L/min' flow meter. The screen is still blank.</p>



Description	Step	Illustration
<p>Self-test screen will appear. Press and hold “BACK” button until calibration mode screen appears.</p>	4	 <p>Firmware Ver. V7RC7.1 0.0399 0 Build Date: 2016-04-11 0.0055 152 Display Ver. 2.12 0.4882 10</p> <p>international BIOMEDICAL®</p> <p>Hold  to Enter Calibration Mode</p>
<p>Press soft key next to “ZERO CAL” to enter zero mode. Wait for 2-3 minutes until all values stabilize.</p> <p>NOTE: <i>If following the initial setup instructions and a calibration per Section 6. was just completed, the AeroNOx 2.0™ does not need to be re-zeroed.</i></p>	5	 <p>Calibration Mode</p> <p>ZERO CAL</p> <p>NO (ppm) NO₂ (ppm) %O₂ HIGH CAL</p> <p>02 0.3 23</p>
<p>Press and hold soft key “ZERO” again until timer completes and “DONE” message appears.</p> <p>Zero calibration does not require calibration gases. Note ambient room %O₂ concentration “zero” is actually 21%.</p>	6	 <p>Calibration Mode</p> <p>Hold to ZERO</p> <p>NO (ppm) NO₂ (ppm) %O₂</p> <p>02 0.3 23</p>
<p>Zero Calibration Completed.</p>	7	 <p>DONE</p> <p>Calibration Mode</p> <p>Hold to Zero</p> <p>NO (ppm) NO₂ (ppm) %O₂</p> <p>0 0 21</p>



Description	Step	Illustration
<p>Turn the AeroNOx 2.0™ Off by pressing and holding the “ON/OFF” button for ~3 seconds.</p>	<p>8</p>	 <p>The illustration shows the front panel of the AeroNOx 2.0 device. A black arrow points to the power button, which is labeled with a power symbol and the text 'ON/OFF'.</p>
<p>Assemble AeroNOx 2.0™ Test Circuit as shown using the following steps with these parts:</p> <ol style="list-style-type: none"> 1. 100% O₂ source 2. Flow meter capable of 10 L/min 3. AeroNOx 2.0™ Test Circuit (738-1889) 4. AeroNOx 2.0™ 5. Calibrated NO gas with regulator and quick disconnect 	<p>9</p>	 <p>The diagram illustrates the AeroNOx 2.0™ Test Circuit. It shows a 100% O₂ gas cylinder connected to a flow meter. The flow meter is connected to the 'Inspiratory Limb NO Titration' port of the AeroNOx 2.0™ device. A distance of > 30 cm is indicated between the flow meter and the device. The 'Inspiratory Limb NO/NO₂ Sampling' port is connected to an 'Exhaust' line. A Nitric Oxide gas supply cylinder (800 ppm) is connected to the 'NO/NO₂' port of the device via a braided stainless steel hose with a quick disconnect.</p>
<p>Connect Test Circuit's delivery line and sample lines to corresponding ports on front of AeroNOx 2.0™.</p>	<p>10</p>	 <p>The close-up photograph shows the front panel of the AeroNOx 2.0™ device. A white delivery line is connected to the 'NO/NO₂' port, and a yellow sample line is connected to the 'Inspiratory Limb NO/NO₂ Sampling' port. The 'ON/OFF' button is visible to the left.</p>

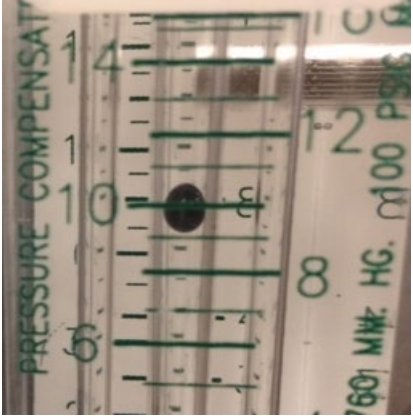

Description	Step	Illustration
<p>Close flow meter valve and connect Test Circuit to oxygen flow meter and 100% O₂ source gas. No gas should be flowing yet.</p> <p><i>NOTE:</i> The source may be a bottle or wall outlet, but must be able to deliver 10 L/min.</p>	11	
<p>Obtain and check NO gas cylinder for proper labels, concentration and expiration date.</p>	12	
<p>Obtain high pressure delivery regulator. Inspect for cracks and chips on sealing O-ring or nipple and replace as necessary. See Section 7.</p>	13	



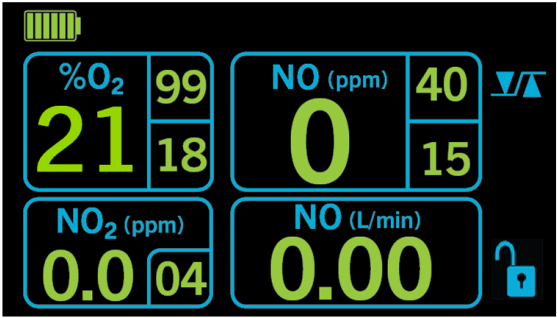

Description	Step	Illustration
Connect regulator to cylinder and hand tighten.	14	
Insert male quick connect on stainless steel NO delivery tubing into the corresponding female connection on regulator.	15	
Open cylinder by rotating valve fully counterclockwise.	16	
Note pressure on regulator.	17	

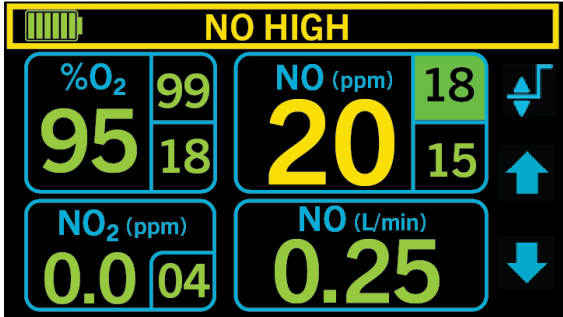

Description	Step	Illustration
<p>Turn cylinder off by rotating valve fully clockwise.</p>	<p>18</p>	
<p>Observe cylinder pressure for 30 seconds, if pressure drop is >100 psi (7 bar), there is significant leakage that must be repaired. Check for leaks at connections using soap and water. If no significant leak is found, then continue.</p>	<p>19</p>	
<p>Close the cylinder if not already closed.</p>	<p>20</p>	
<p>Purge regulator and stainless NO supply hose using the purge pin on the back of the AeroNOx 2.0™. Open the cylinder to re-pressurize line, then purge for 5-10 seconds.</p>	<p>21</p>	

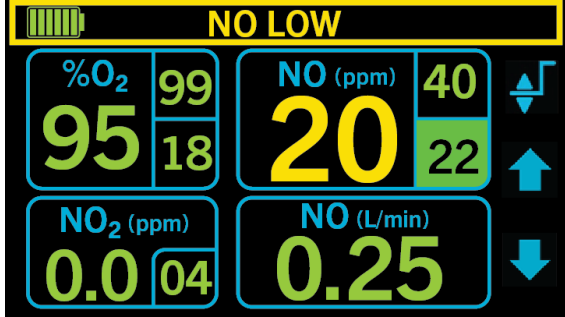

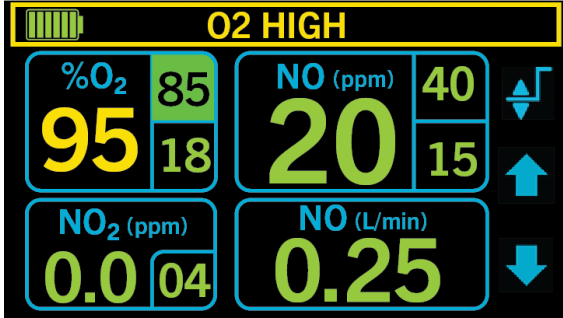

Description	Step	Illustration
<p>Make sure the AeroNOx 2.0™ is still off and connect stainless steel NO supply hose to NO/N₂ Gas Inlet quick disconnect.</p>	<p>22</p>	
<p>Open flow meter valve and set O₂ flow through Test Circuit to 10 L/min.</p>	<p>23</p>	
<p>Rotate NO flow control fully clockwise to Off.</p>	<p>24</p>	
<p>Turn the AeroNOx 2.0™ on by pressing the "ON/OFF" button for ~1 second.</p>	<p>25</p>	

Description	Step	Illustration
<p>Self-test screen will again appear followed by the main screen. “Zero” values obtained previously should be shown. NO (L/min) should be zero.</p>	26	
<p>Rotate NO flow control counter-clockwise until NO flow reads 0.25 L/min.</p>	27	
<p>Allow values to stabilize for at least 1 minute then compare values to acceptable range.</p> <p>If monitored values are outside the acceptable range, do a High Cal. (See Section 6.)</p>	28	<p>ACCEPTABLE RANGE: NO 15-25 ppm NO₂ <1.5 ppm %O₂ 95 ±5%</p>
<p>Press “Set High/Low Alarm” control soft key.</p>	29	

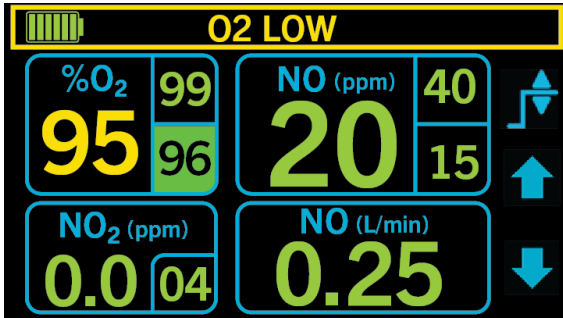
Description	Step	Illustration
<p>Press “NO” control key. NO High alarm limit becomes highlighted.</p>	30	
<p>Set NO High alarm level 2 ppm below displayed NO value using “UP/DOWN” arrow keys. Alarm should sound.</p>	31	
<p>Set NO High alarm to 40 ppm using “UP ARROW” soft key. Alarm should stop.</p>	32	
<p>Press “Set Low Alarm” control soft key. NO Low alarm limit becomes highlighted.</p>	33	

Description	Step	Illustration
<p>Set NO Low alarm level 2 ppm above displayed NO value using “UP/DOWN” arrow keys. Alarm should sound.</p>	34	
<p>Set NO Low alarm to 5 ppm using “UP/DOWN” arrow keys. Alarm should stop.</p>	35	
<p>Press back button control key</p>	36	
<p>Press “O₂” soft key. %O₂ High alarm limit becomes highlighted.</p>	37	

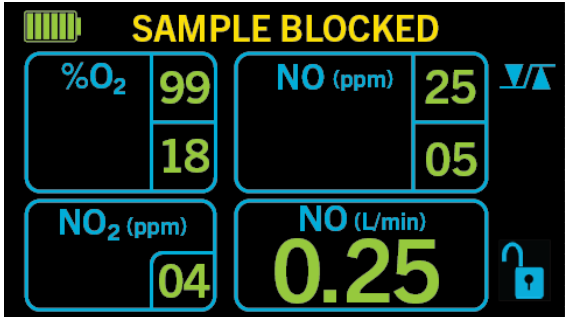
Description	Step	Illustration
<p>Set %O₂ High alarm limit to 85% using “UP/DOWN” arrow keys. Alarm should sound.</p>	38	
<p>Set %O₂ High alarm limit to 100% using “UP/DOWN” arrow keys. Alarm should stop.</p>	39	
<p>Press “Set Low Alarm” control soft key. %O₂ low alarm limit becomes highlighted.</p>	40	
<p>Set %O₂ Low alarm limit to 1% above displayed value using “UP/DOWN” arrow keys.</p>	41	

Description	Step	Illustration
Set %O ₂ Low alarm limit back to 18% using “UP/DOWN” arrow keys.	42	
Press “BACK” button control key two times.	43	
Main screen should now be displayed.	44	
Block sample line flow by kinking tubing at smooth bore portion. Alarm should sound indicating SAMPLE BLOCKED and NITRIC OFF.	45	
Unkink tubing. Press and hold “ON/OFF” button for ~3 second then push again to cycle power to reset.	46	

Description	Step	Illustration
If AeroNOx 2.0™ is not going to be used, perform the following:	47	<ol style="list-style-type: none"> 1. Turn NO cylinder off. 2. Allow oxygen to flow for 30 seconds, and then turn flowmeter to off. 3. Remove Test Circuit from flowmeter and AeroNOx 2.0™. 4. Disconnect stainless steel delivery line from the back of AeroNOx 2.0™. 5. Press power key and turn AeroNOx 2.0™ off. 6. Disconnect Stainless steel delivery line from regulator. 7. Remove regulator from NO cylinder. 8. Properly stow all equipment for later use.
If AeroNOx 2.0™ is going to be used, perform the following:	48	<ol style="list-style-type: none"> 1. Turn NO cylinder off. 2. Allow oxygen to flow for 30 seconds, and then turn flowmeter to off. 3. Disconnect Test Circuit from flowmeter and AeroNOx 2.0™. 4. Refer to Section 3.

3. PATIENT OPERATIONS

3.1. Before Operation

Complete pre-use procedures outlined in the Section 2. before connecting the AeroNOx 2.0™ to the patient's ventilator breathing circuit.

3.2. Connection to Ventilator Circuit (General)

Connect the AeroNOx 2.0™ into the breathing circuit as shown in the appropriate connection diagrams. In general, the connection is as follows:

1. Splice the delivery line tee into the inspiratory limb of the ventilator circuit.
2. Splice the sample line tee into the inspiratory limb of the ventilator circuit so:
 - a. The distance between the delivery tee and sample tee is 30-40 cm (12-15 in).
 - b. The distance between the sample tee and the patient wye is at least 15-30 cm (6-12 in).

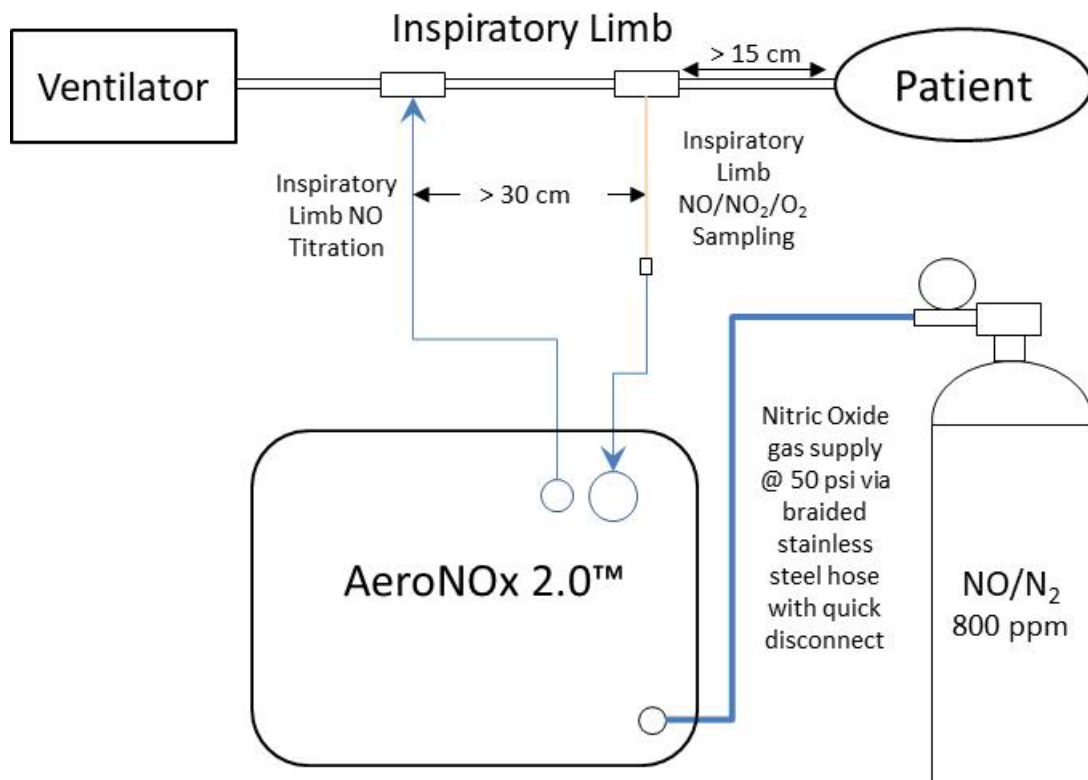

3.3. INOstat Bagger backup NO Delivery System



The INOstat Kit is used to continue NO delivery in the event of electronic or mechanical failure of the ventilator or AeroNOx 2.0™ NO delivery system. The system consists of the INOstat Bagger and backup delivery regulator.



The INOstat Bagger is a manually operated, completely pneumatic device that does not depend on the AeroNOx 2.0™ to function.

When connected to an NO cylinder, 0.25 L/min of NO gas is injected into the INOstat Bagger. When the INOstat Bagger is simultaneously connected to an oxygen gas source at 10 L/min, a 20 ppm concentration can be manually delivered to the patient.

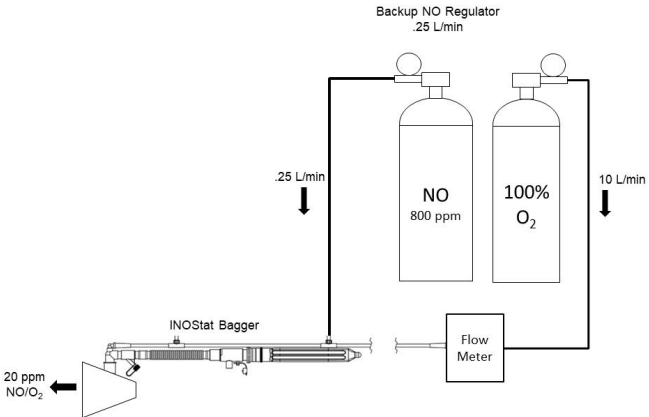
3.4. INOstat Kit Pre-Use Checkout

Description	Step	Illustration
<p>Obtain and check NO gas cylinder for proper labels, concentration, and expiration date.</p>	<p>1</p>	
<p>Obtain high pressure backup delivery regulator preset to deliver 0.25 L/min NO.</p>	<p>2</p>	
<p>Inspect sealing O-ring or nipple for cracks and chips, replace as necessary.</p>	<p>3</p>	
<p>Connect regulator to NO cylinder and hand tighten.</p>	<p>4</p>	

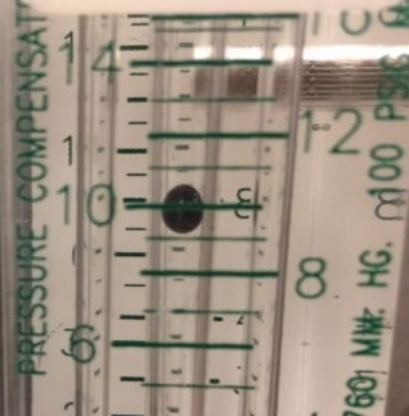
Description	Step	Illustration
<p>Obtain INOstat Bagger. 731-9919 (5-Pack)</p>	<p>5</p>	
<ol style="list-style-type: none"> 1. Connect oxygen tubing from INOstat Bagger to oxygen flowmeter. 2. Connect INOstat Bagger delivery line to backup regulator. 3. Verify gas sample connector is capped if present. 	<p>6</p>	
<p>Connect test lung to INOstat Bagger.</p>	<p>7</p>	

Description	Step	Illustration
<p>Set O₂ flowmeter to 10 L/min. Let oxygen flow for 30 seconds to flush system.</p>	8	
<p>Open NO cylinder by turning valve fully counterclockwise.</p>	9	
<p>Adjust outflow from bag by rotating valve until desired inflation is achieved. Squeeze INOstat Bagger bag and verify test lung inflates.</p>	10	
<p>INOstat Bagger pre-use checkout is complete, perform the following:</p>	11	<ol style="list-style-type: none"> 1. Close NO cylinder. 2. Remove backup regulator from NO cylinder. 3. Allow O₂ to flow for 30 seconds to flush INOstat Bagger system then turn O₂ off. 4. Stow system where it is accessible for emergency use

3.5. INOstat Kit Instructions for Use

1. Ensure pre-use checkout has been performed.
2. Connect oxygen tubing from INOstat Bagger to O₂ flowmeter.
3. Connect INOstat Bagger delivery line to backup regulator.
4. Verify gas sample connector is capped.
5. Connect backup regulator to NO cylinder and hand tighten.
6. Set O₂ flowmeter to 10 L/min.
7. Let oxygen flow for 30 seconds to flush system.
8. Connect test lung to INOstat Bagger.
9. Adjust outflow from bag by rotating valve until desired inflation of test lung is reached.
10. Begin manually ventilating patient. The delivered dose will be 20 ppm.

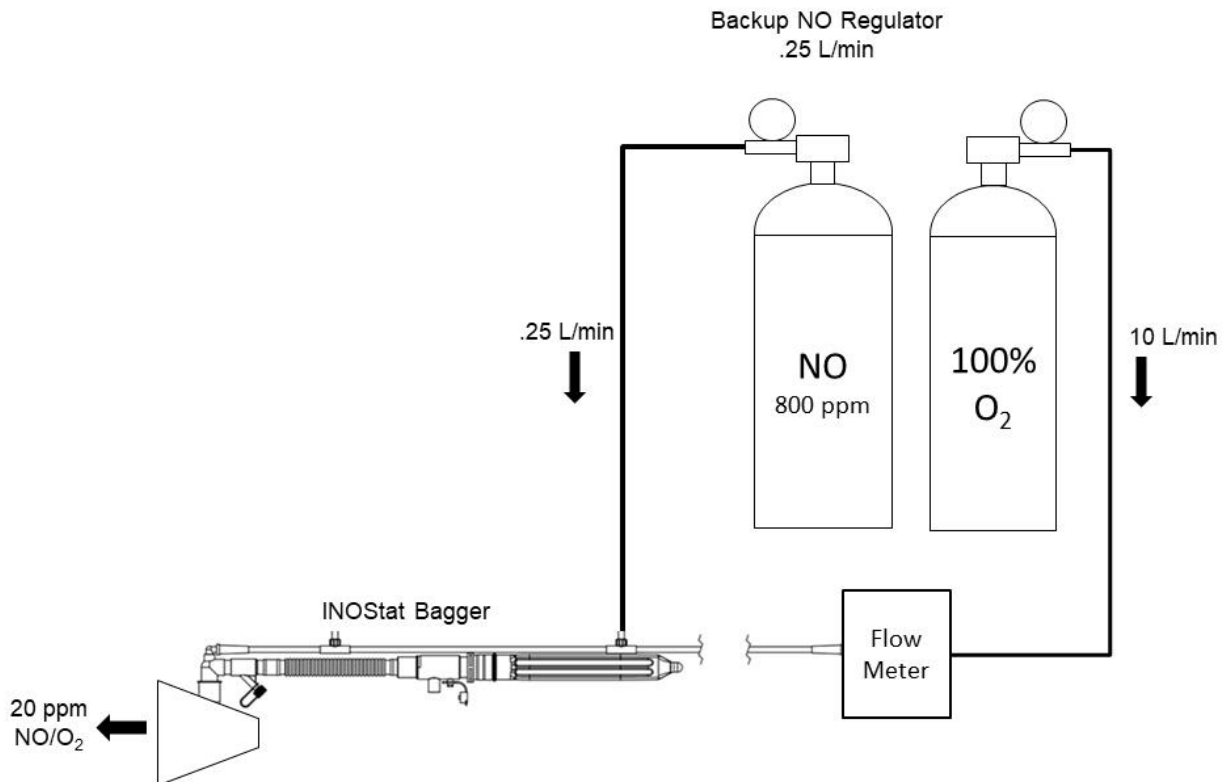

3.6. Connection to Various Breathing Systems

3.6.1. **Conventional Sample/Delivery Kit, AeroNOx 2.0™**



The Sample/Delivery Line Kit contains one sample line and one delivery line. The sample line is used to connect the AeroNOx 2.0™ to the inspiratory limb of a ventilator breathing circuit approximately 20-30 cm (10-12 in) upstream of the patient wye.

The AeroNOx 2.0™ side of the sample line is a quick disconnect 5-micron hydrophobic filter. Push into the sample port to connect. Press the release button and pull to remove. The other end of the sample line has Nafion® tubing for removing condensing humidity. It connects to an inline tee or other sample line adapter, pending identification of what ventilator is being used.

The Delivery Line is used to connect the AeroNOx 2.0™ to the inspiratory limb of the ventilator breathing circuit approximately 20-30 cm upstream of the Sample Line.

To connect the delivery line, push the quick disconnect onto the delivery fitting. Pinch the fitting at the blue buttons to release. The other end of the sample line can connect to an inline tee or other sample line adapter, pending identification of what ventilator is being used.

3.7. Connection Diagram - ICU Ventilator Circuit

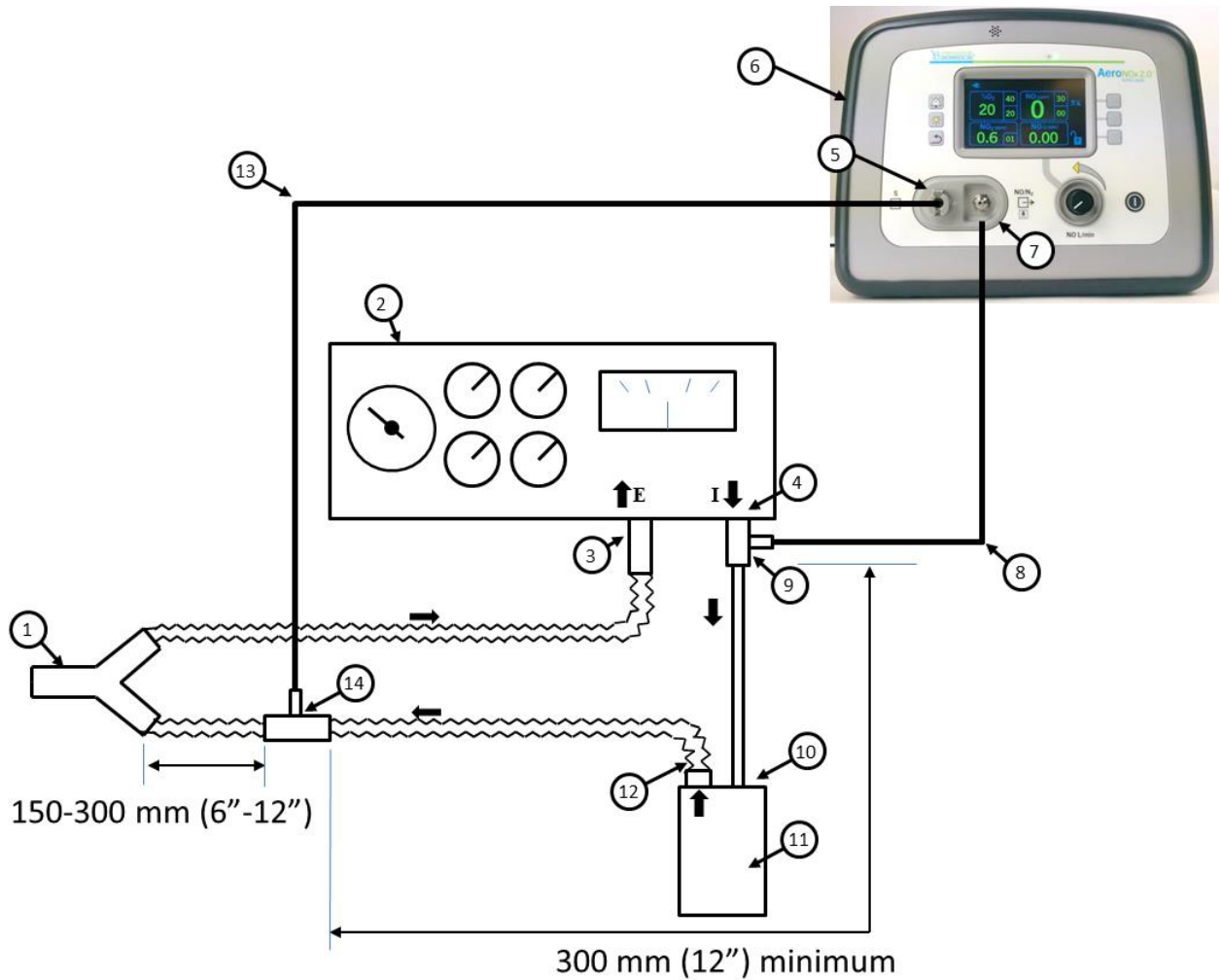

1	Patient Wye
2	Ventilator
3	Ventilator Expiratory Port
4	Ventilator Inspiratory Port
5	Gas Sample Input Connection
6	AeroNOx 2.0™
7	Gas Delivery Port Connection
8	Patient Gas Delivery Line
9	Delivery Tee
10	Humidifier Inlet (Optional)
11	Humidifier (Optional)
12	Humidifier Outlet (Optional)
13	Patient Gas Sample Line
14	Gas Sample Tee

3.7.1. Steps to Connect to an ICU Ventilator Circuit

1. Perform pre-use checkout and alarm verification, Section 2.
2. Attach NO Worries sample and delivery lines to AeroNOx 2.0™ and ventilator circuit per Section 3.
3. Connect test lung to ventilator wye.
4. Set-up ventilator per hospital guidelines.
5. Ventilate test lung.
6. Inactivate Safety Shut Off System (Section 4., ALARMS).
7. Turn on NO gas cylinder.
8. Note approximate flow rate on ventilator
9. Calculate approximate NO flowrate using the following formula:

$$\text{NO Flow (LPM)} = \frac{\text{Vent Flow (LPM)} \times [\text{NO}]_{\text{Desired}}}{\text{Source } [\text{NO}]_{\text{in Tank}}}$$

10. Once NO has stabilized and NO₂ is at an acceptable level, adjust NO flow for desired NO ppm.
11. Calculated NO flow should be compared with analyzed NO dose. If there is >10% difference between the two, the cause must be determined and corrected immediately (Section 5., CALCULATIONS & TROUBLESHOOTING).
12. Activate Safety Shut Off System (Section 4., ALARMS).
13. Connect ventilator to patient according to institution protocol.

3.8. Connection Diagram - Transport Ventilator Circuit

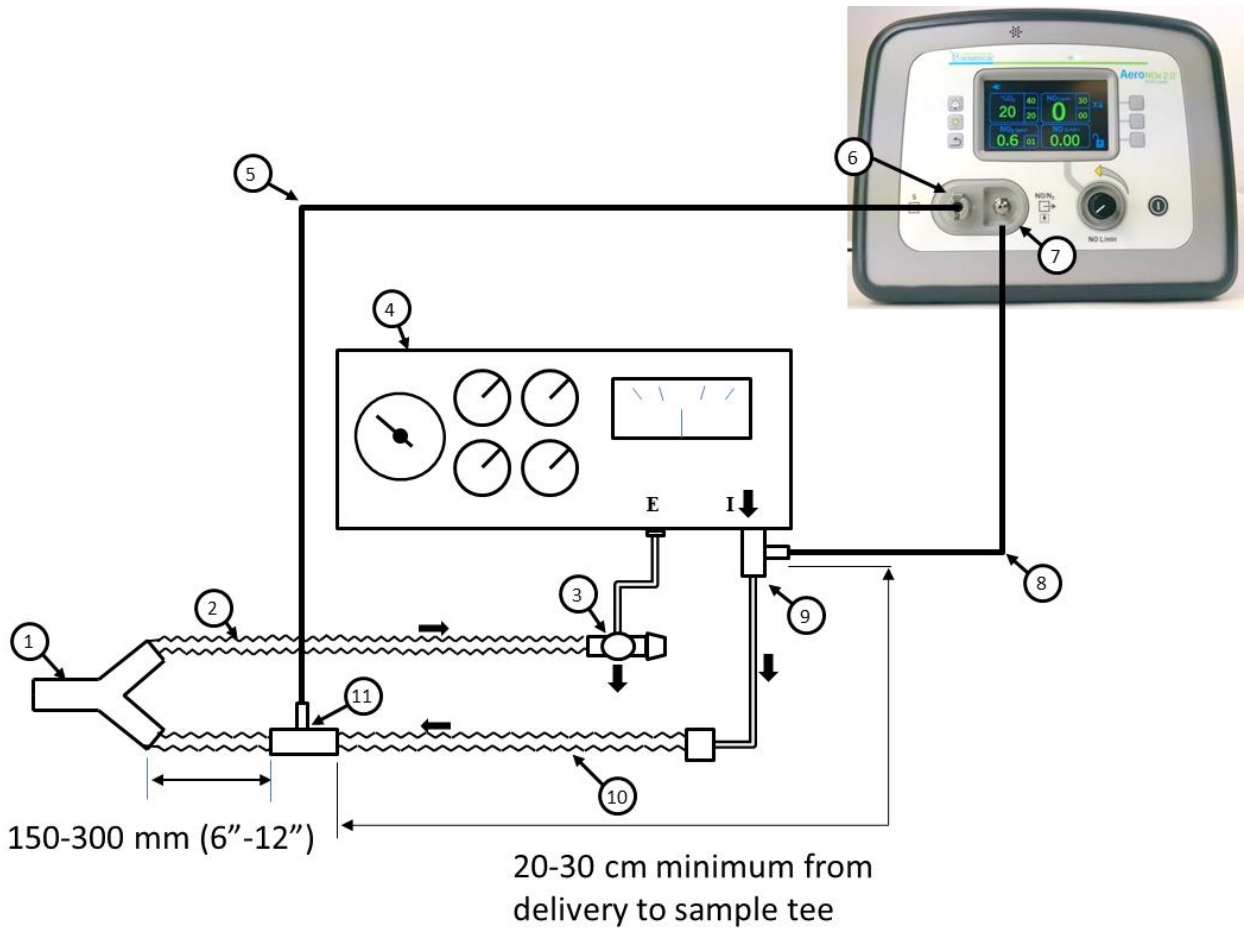

1	Patient Wye
2	Ventilator Expiratory Limb
3	Exhalation Valve
4	Ventilator
5	Gas Sample Line
6	Gas Sample Port Connection
7	Gas Delivery Port Connection
8	Delivery Line
9	Delivery Tee
10	Inspiratory Limb
11	Gas Sample Tee

3.8.1. Steps to Connect to a Transport Ventilator Circuit

1. Perform pre-use checkout and alarm verification, Section 2.
2. Attach NO Worries sample and delivery lines to AeroNOx 2.0™ and ventilator circuit per Section 3.
3. Connect test lung to ventilator wye.
4. Set-up ventilator per hospital guidelines.
5. Ventilate test lung.
6. Inactivate Safety Shut Off System (Section 4., ALARMS).
7. Turn on NO gas cylinder.
8. Take note of flowrate set on the ventilator.
9. Calculate approximate NO flowrate using the following formula:

$$\text{NO Flow (LPM)} = \frac{\text{Vent Flow (LPM)} \times [\text{NO}]_{\text{Desired}}}{\text{Source } [\text{NO}]_{\text{in Tank}}}$$

10. Once NO has stabilized and NO₂ is at an acceptable level, adjust NO flow for desired NO ppm.
11. Calculated NO flow should be compared with analyzed NO dose. If there is >10% difference between the two, the cause must be determined and corrected immediately, see Section 5., CALCULATIONS & TROUBLESHOOTING.
12. Activate Safety Shut Off System (Section 4., ALARMS).
13. Connect ventilator to patient according to institution protocol.

3.9. Connection Diagram - High Frequency TXP-2D Phasitron

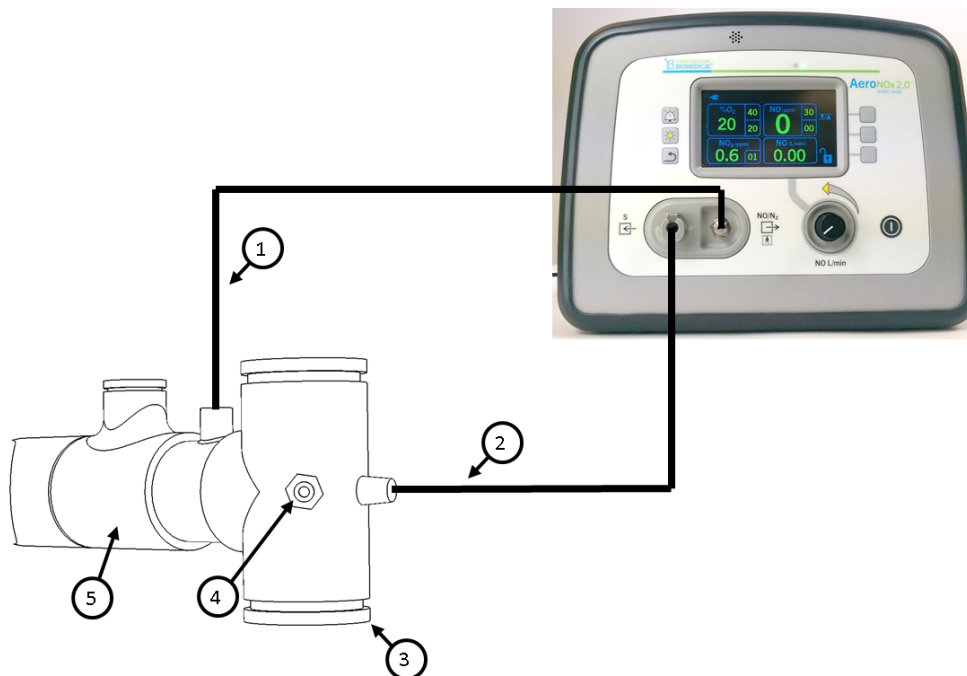

1	Gas Delivery Line
2	Gas Sample Line
3	Patient Connection
4	Proximal Airway Port
5	Phasitron

3.9.1. **Steps to Connect to a High Frequency TXP-2D Phasitron**

1. Perform pre-use checkout and alarm verification, Section 2.
2. Replace standard Phasitron swivel tee with NO swivel tee (if applicable).
3. Connect NO Worries delivery and sample line to AeroNOx 2.0™.
4. Connect AeroNOx 2.0™ delivery line to Phasitron.
5. Connect AeroNOx 2.0™ sample line to Phasitron.
6. Connect proximal airway port from TXP-2D unit to proximal airway monitoring port on the Phasitron.
7. Connect to TXP-2D to test lung.
8. Set desired TXP-2D settings.
9. Inactivate Safety Shut Off System (Section 4., ALARMS).
10. Turn on NO gas cylinder.
11. Set desired AeroNOx 2.0™ settings (Start at 0.25 L/min).
12. Once NO has stabilized and NO₂ is at an acceptable level, adjust NO flow for desired NO ppm.
13. Activate Safety Shut Off System (Section 4., ALARMS).
14. Connect ventilator to patient according to institution protocol.

3.10. Connection Diagram - AeroNOx 2.0™ Bagger

The AeroNOx 2.0™ Bagger is used to continue NO delivery in place of, or in the event of electronic or mechanical failure of, the ventilator.

The AeroNOx 2.0™ Bagger is intended to be connected directly to the patient's endotracheal tube.

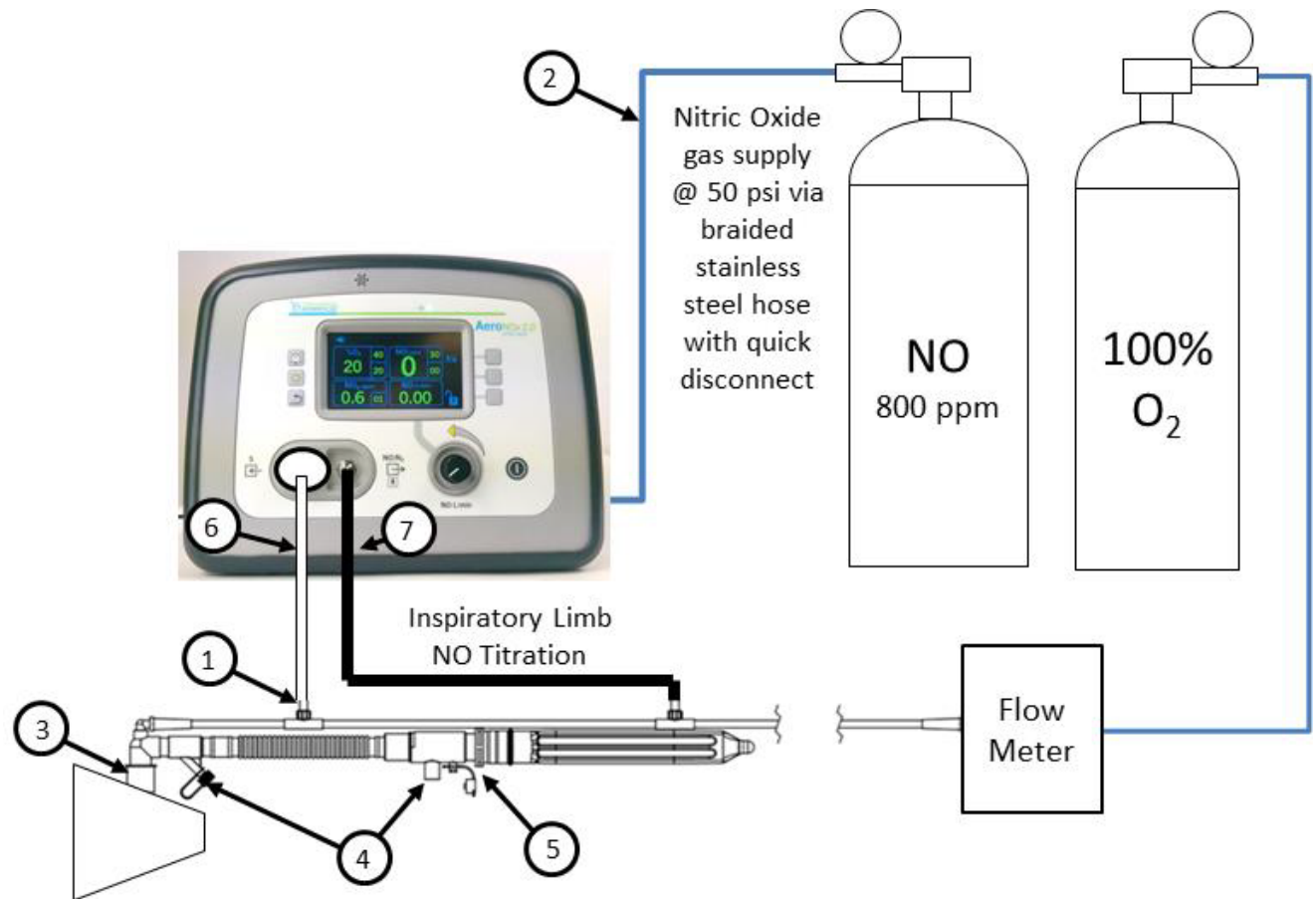

1	Gas Sample Port
2	Gas Supply Tubing
3	Patient Connection
4	Proximal Airway Ports
5	Adjustable Flow Valve
6	Gas Sample Line
7	Gas Delivery Line

3.10.1. Steps to Connect to AeroNOx 2.0™ Bagger

1. Ensure pre-use checkout has been performed, Section 2.
2. Connect oxygen tubing from AeroNOx 2.0™ Bagger to oxygen flowmeter.
3. Connect AeroNOx 2.0™ Bagger delivery line to AeroNOx 2.0™.
4. Connect AeroNOx 2.0™ Bagger sample line to AeroNOx 2.0™.
5. Connect test lung to AeroNOx 2.0™ Bagger.
6. Set O₂ flowmeter to 10 L/min.

7. Adjust outflow from bag by rotating valve until desired inflation of test lung is reached.
8. Let oxygen flow for 30 seconds to flush system.
9. Set NO flow on AeroNOx 2.0™ to 0.25 L/min.
10. Adjust settings as necessary.
11. Wait for all parameters to stabilize.
12. Connect AeroNOx 2.0™ Bagger to patient and follow institution protocols.

4. **ALARMS**

4.1. General Alarm Information

A listing of alarm messages is provided at the end of this section.

All alarms have audible tones with associated visual cues.

4.2. Priority Alarms

The following table provides the audible alarm tone information for low, medium, and high priority alarms. Volume is not adjustable.

AUDITORY ALARM TONES			
PRIORITY	DESCRIPTION	COMMENT	
High	10 Pulse Burst	Repeats if not silenced	
Medium	3 Pulse Burst	Repeats if not silenced	
Low	1 Pulse Burst	Repeats if not silenced	
VISUAL ALARM CUES			
PRIORITY	FREQUENCY	Color	Duty Cycle
High	2.1 Hz	Red	20% to 60% on
Medium	0.6 Hz	Yellow	20% to 60% on
Low	Constant (On)	Yellow	100% on

4.3. Alarm Silencing



Pushing the alarm silence button silences existing alarms for 60 seconds. When silenced, the alarm silence icon will appear as shown below.

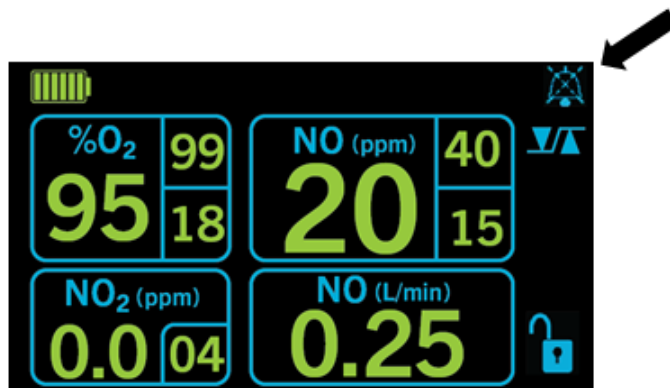

If a new alarm condition occurs, the icon disappears and the audible alarm becomes active again.

Pushing the alarm silence button  while alarms are silenced will cancel the alarm silence.

Pushing the alarm silence button  with no active alarms will have no effect.

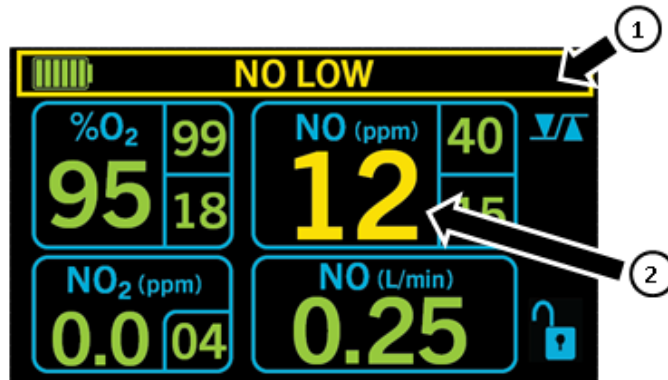

1	Alarm Silence Icon Cleared
2	Violated Value Alarm Limit

4.4. User Adjustable Monitor Alarms

The NO, NO₂, and O₂ monitors have adjustable alarm settings that are displayed to the side of the monitored value. When an alarm occurs for %O₂ below 18%, the displayed value flashes red.

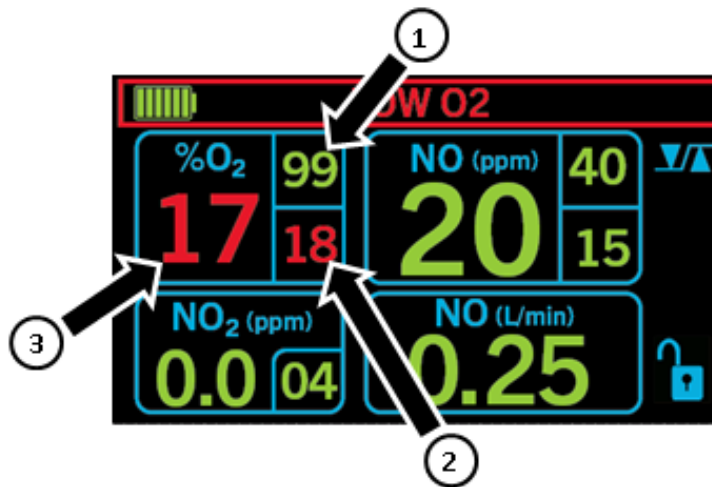

1	High Alarm Setting
2	Low Alarm Setting
3	Violated Alarm Setting

1. To adjust an alarm level to a new value, press alarm control key.
2. Press key of desired parameter NO, NO₂, or O₂ to be changed.
3. High alarm limit of parameter selected becomes highlighted.

4. Use up/down arrows to adjust to the new level.
5. Press alarm control key.
6. Low alarm limit of parameter selected becomes highlighted.
7. Use up/down arrows to adjust low alarm limit to the new level.
8. Press back button key twice to enter main screen.

The adjustment range for these alarm settings are shown in the table below.

Alarm	Adjustment	Default	Priority
High NO (ppm)	1-99	30	Medium
Low NO (ppm)	1-99	10	Low
High NO ₂ (ppm)	0-9	01	High
High O ₂ (%)	21-100	40	Medium
Low O ₂ (%)	19-99	20	Medium
Low O ₂ (%)	18	18	High
Nitric Off	Auto	NO + 5 ppm above High NO alarm setting or 99 ppm whichever is lesser value.	Medium
Nitric Off	Auto	NO ₂ + 1 ppm above High NO ₂ alarm or 9 ppm whichever is lesser value.	High

4.5. Safety Shut Off

The AeroNOx 2.0™ has an incorporated safety shut off system for NO gas. The system is designed to avoid inadvertent high doses of NO being delivered to the patient. The system is activated by either NO or NO₂ analyzed levels. First, if the NO concentration measured is 5 ppm above high set alarm value or 99 ppm whichever is the lesser value, NO delivery will cease. Second, if the NO₂ concentration measured is 1 ppm above that which has been set on the high NO₂ alarm or 9 ppm whichever is the lesser value, NO delivery will cease. The system will restore NO delivery if analyzed NO or NO₂ values drop back below 5 ppm and 1 ppm alarm levels respectively. The default of the safety shut off system is activated; no action is required to enable the safety system.

If the safety shut off is activated, an alarm will occur with audible and visual alarms in addition to a "NITRIC OFF" message. During this time the patient will not be receiving NO gas and it is recommended to manually ventilate using the backup NO delivery system outlined in Section 3.

During AeroNOx 2.0™ setup, it may be necessary to override the safety shut off system until monitored gases equilibrate and stabilize. To override or deactivate the safety shut off, press and hold the Alarm Silence and Back keys simultaneously for 5 seconds. The monitor screen will continuously flash "SAFETY OFF". "SAFETY ON" will automatically be restored after 5 minutes or press and hold the Alarm Silence and Back keys simultaneously for 5 seconds. Additionally, if AeroNOx 2.0™ is turned off and then back on "SAFETY ON" will be restored.



4.6. Alarm Table

The following alarm table provides a list of the systems alarms along with a graphic representation. (See Section 5., CALCULATIONS & TROUBLESHOOTING, for a description of each alarm).

High Priority Alarms	
O ₂ < 18%	
NO ₂ High NO ₂ > NO ₂ limit + 1 ppm (Alternating)	
NO ₂ High NO ₂ > NO ₂ limit	

Medium Priority Alarms	
NO High NO > NO limit + 5ppm (Alternating)	
NO High NO > NO limit	
Sample line Blocked	
Power Supply Failure (Alternating)	

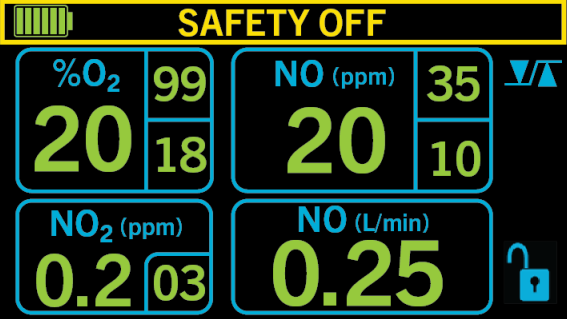
Low Priority Alarms	
Low Battery	
NO Low	

Other Messages		
SAFETY OFF		 <p>The display shows a battery level icon, the text "SAFETY OFF", and four data boxes: %O₂ (99/20/18), NO (ppm) (35/20/10), NO₂ (ppm) (0.2/03), and NO (L/min) (0.25). A lock icon is visible on the right side.</p>
SAFETY ON		 <p>The display shows a battery level icon, the text "SAFETY ON", and four data boxes: %O₂ (99/20/18), NO (ppm) (35/20/10), NO₂ (ppm) (0.2/03), and NO (L/min) (0.25). A lock icon is visible on the right side.</p>
INTERNAL ERROR		<p>INTERNAL ERROR</p> <p>An internal error has occurred. Please reboot the system and attempt the operation again. If the error persists, please contact International Biomedical for technical support.</p> <p>ERROR CODE: 0x01</p>

5. CALCULATIONS & TROUBLESHOOTING

1. **CALCULATIONS FOR NITRIC OXIDE DELIVERY**

Where to start?

How to estimate initial NO flow

What is the diluted FiO₂?

Estimating your FiO₂ after dilution with NO gas

How are we doing?

Oxygen Index Calculation

2. **CYLINDER DURATION NOMOGRAMS**

How long will this tank last?

3. **AERONOX 2.0™ TROUBLESHOOTING GUIDE**

When all else fails, read the manual...

5.1. Calculations for Nitric Oxide Delivery

5.1.1. **Where to start?**

It is imperative that you determine what NO flow to set, and what the NO flow reading should be during NO administration for the desired dose.

To determine the initial nitric oxide (NO) flow rate, given your NO source gas concentration, [NO], ventilator minute ventilation & desired NO dose, use the formula below.

To determine NO flow for use with the AeroNOx 2.0™ Bagger or other respiratory gas administration systems, substitute O₂ flow for ventilator flow in the equation below.

$$\text{Initial NO Flow (LPM)} = \frac{\text{Vent Flow (LPM)} \times \text{Desired [NO]ppm}}{\text{Source Tank [NO]ppm}}$$

Example:

Minute volume, or ventilator flow = 10 LPM.

Nitric oxide source tank = 800 ppm

You want to deliver 25 ppm to your patient.

$$\text{Initial NO Flow (LPM)} = \frac{10 \text{ LPM} \times 25 \text{ ppm Desired [NO]}}{800 \text{ ppm Tank [NO]}} = \frac{250}{800} = 0.31 \text{ LPM}$$

Set 800 ppm NO source gas flow @ 0.31 LPM to get ~ 25 ppm NO diluted in 10 LPM fresh gas flow.

The chart below was developed using the previous calculations. You may use it as a starting point for setting your NO flow rate. **Please note that these are reference points only. The actual dose delivered must be measured by the analysis portion of the AeroNOx 2.0™.**

Minute Volume / Ventilator / Bagger Flow

[NO]	5	10	15	20
5 ppm	0.03	0.06	0.09	0.13
10 ppm	0.06	0.13	0.19	0.25
20 ppm	0.13	0.25	0.38	0.50
40 ppm	0.25	0.50	0.75	1.00
80 ppm	0.50	1.00	1.50	2.00

NO Flow in LPM

The following table represents the average NO₂ value measured at a FiO₂ of 1.0 during testing with the ventilators listed in this manual. Use it as a reference for what NO₂ values you can expect when delivering the NO concentrations listed in the column on the left.

Minute Volume / Ventilator Flow

[NO]	5	10	15	20
5 ppm	0.5	0.1	0.1	0.1
10 ppm	0.5	0.2	0.2	0.1
20 ppm	0.5	0.3	0.2	0.2
40 ppm	0.8	0.6	0.4	0.4
80 ppm	2.0	1.5	1.2	1.1

NO₂ in ppm

The tables above are for reference only. Factors such as the accuracy of the ventilator flow, percent error in delivery apparatus, and human error, may all affect the actual delivered patient dose. The calculated NO flow should be compared with the analyzed NO dose to confirm accurate NO dosing. Should the actual NO flow differ from the calculated NO flow by more than 10% beyond published specifications, the cause must be determined and corrected immediately. If the cause cannot be immediately determined, ensure patient safety and contact International Biomedical at 1-512-873-0033 for further assistance.

CAUTION!

NO flow must be continually evaluated during nitric oxide administration to ensure accurate dosing!

5.1.2. What is the diluted FiO₂?

Estimating your FiO₂ after dilution with NO gas, given your NO flow setting, and total ventilator gas flow

$$\text{Estimated FiO}_2 = \text{Initial FiO}_2 - (\text{NO Flow} / \text{Total Flow O}_2 + \text{Total NO Flow}) \times 100$$

Example:

- Initial FiO₂ = 1.0 (100%)
- NO flow = 0.31 LPM (800 ppm gas, bal Nitrogen)
- Ventilator flow = 10 LPM
- Total flow = 10.31 LPM

$$\begin{aligned}\text{Estimated FiO}_2 &= 1 - (0.31 / 10.31 \text{ LPM}) = 0.97 \\ \text{Estimated \% O}_2 &= 1 - (0.31 / 10.31 \text{ LPM}) \times 100 = 97\%\end{aligned}$$

- **When delivering ~ 25 ppm NO (~ 0.31 LPM) in ~ 10 LPM of 100% oxygen, you can expect the % O₂ to be diluted by ~ 3%.**
- **In this case, the maximum FiO₂ you can expect is ~ 0.97.**

5.1.3. How are we doing?

Oxygen Index Calculation:

$$\text{Oxygen Index (OI)} = \text{Paw} \times \text{FiO}_2 \times 100 / \text{PaO}_2, (\text{mmHg})$$

Interpretation: Most centers interpret less than 15 as good.

- Mean airway pressure in cmH₂O = Paw
- Fraction of inspired oxygen = FiO₂
- Arterial oxygen tension in mmHg = PaO₂

Example: Pre nitric oxide Data

- FiO₂ = 1.0 (100%)
- PaO₂ = 65 mmHg
- Paw (Mean Airway Pressure) = 15 cmH₂O

$$\text{Oxygen Index (OI)} = 15 \times 1 \times 100 / 65 = 23$$

Post nitric oxide Data

- FiO₂ = 0.55 (55%)
- PaO₂ = 75 mmHg
- Paw = 12 mmHg

$$\text{Oxygen Index (OI)} = 12 \times 0.55 \times 100 / 75 = 8.8$$

In this example, OI improved markedly (23 to 8.8) after inhaled nitric oxide administration.

5.1.4. Calculation of Cylinder Duration

How long will this tank last?

- The volume of gas in your cylinder(s) is a function of the filling pressure and the capacity (size) of the cylinder. For compressed gases, this relationship is linear and can be expressed as a tank factor which is equal to cylinder volume / pressure expressed in LPM.

5.2. Gas Supply

e.g. Large NO Cylinders

- Capacity (L): 2040
- Maximum Pressure (full): 2000 psig

$$\text{Tank Factor} = \frac{2040 \text{ L}}{2000 \text{ psig}} = 1.02 \text{ L/psig}$$

The amount of therapeutic gas remaining in a cylinder can be estimated in minutes or hours, provided that three things are known:

1. **Tank Factor**
2. **Tank Pressure**
3. **Flow Rate**

$$\text{Cylinder Duration (Minutes)} = \frac{\text{Cylinder Pressure (psig)} \times \text{Factor (L/psig)}}{\text{Flow Rate (LPM)}}$$

The two following nomograms can be used to estimate cylinder duration.

CYLINDER DURATION

Below you will find an example of how to determine cylinder duration based on the following:

- Rounded down to the nearest quarter hour
- Based on set flow rate and tank pressure
- Time listed is time to run the cylinder dry (cylinders should be changed out at 250 psig)

e.g. #1 - Cylinder Duration for a Cylinder with 2040 L @ 2000 psig

- Tank Factor = 2040 L Cylinder @ 2000 psig = 1.02 L/psig

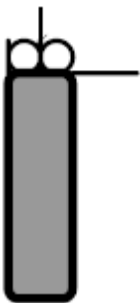

Flow Rate (LPM)

Pressure	.125	.25	.5	.75	1.0	1.5
2000	272	136	68	45.25	34	22.5
1500	204	102	51	34	25.5	17
1000	136	69	34	22.5	17	11.25
500	68	34	17	11.25	8.5	5.5
250	34	17	8.5	5.5	4.25	2.75

Time in Hours

How much calibration gas do I need?

Calibration gas regulators have a preset flow of 0.5 LPM. Since sensor stabilization usually takes ~ 2 - 4 minutes, one sensor calibration should take ~ 2 - 4 minutes and use ~ 2 L of calibration gas.

AeroNOx 2.0™ Fails to Operate Properly:

1. Check patient (if applicable) and take action according to institution protocol.
2. Verify system is setup properly and pre-use check as outlined in Section 2. and Section 3.
3. If necessary use INOstat Bagger see Section 2.
4. Find alarm or message in troubleshooting table and follow recommended actions.
5. If problem cannot be corrected, contact customer service at International Biomedical.

5.3. Troubleshooting Guide

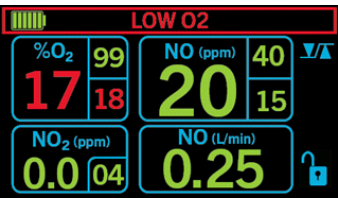
High Priority Alarms		
High Priority Alarms	Possible Cause	Recommended Action
 <p>O₂ Low < 18%</p>	1. Alarm is set inappropriately	Make sure alarm is set appropriately for the O ₂ setting delivered on the ventilator.
	2. O ₂ calibration may have drifted.	<ol style="list-style-type: none"> a. Perform a low and high range calibration on the O₂ sensor. b. Change the O₂ sensor if the unit fails to calibrate. c. Contact International Biomedical Tech Support.
	3. The O ₂ sensor may not be seated properly	Make sure sensor is seated with O-ring sealing to manifold.
	4. O ₂ displaced by NO, N ₂ , or NO ₂ in ventilator circuit.	Remove patient from circuit and ventilate with INOstat Bagger.

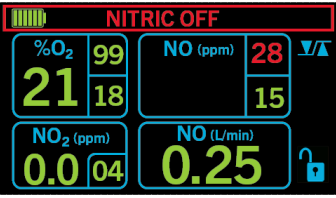
High Priority Alarms		
High Priority Alarms	Possible Cause	Recommended Action
 <p>Nitric Off</p>	1. NO analyzed has exceeded set high NO alarm limit by 5 ppm.	a. Disconnect patient and manually ventilate with INOstat Bagger. Section 3. b. See NO high alarm recommended action above.
	2. NO analyzed has exceeded 99 ppm	a. Disconnect patient and manually ventilate with INOstat Bagger. Section 3. b. See NO high alarm recommended action above.
	3. NO ₂ analyzed has exceeded set high NO ₂ alarm limit by 1 ppm.	a. Disconnect patient and manually ventilate with INOstat Bagger. Section 3. b. See NO ₂ high alarm recommended action above.
	4. NO ₂ analyzed has exceeded 9ppm.	a. Disconnect patient and manually ventilate with INOstat Bagger. See Section 3. b. See NO ₂ high alarm recommended action above.

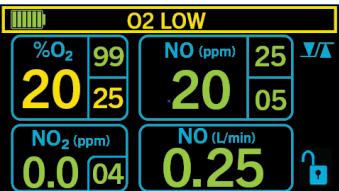

High Priority Alarms		
High Priority Alarms	Possible Cause	Recommended Action
 <p>NO₂ High</p>	1. Incomplete purge of system.	Perform purge. See Section 2., PRE-USE CHECKOUT/ALARM VERIFICATION.
	2. Ventilator flow stopped	Allow ventilator gas to flush circuit and stabilize before connecting to patient.
	3. NO ₂ alarm limit is set too low.	Make sure NO ₂ alarm limit is set to appropriate level.
	4. NO ₂ calibration may have drifted.	Perform a low and high range calibration on the NO ₂ sensor.
	5. Out of date or wrong calibration gas used.	a. Verify gas calibration date. b. Replace calibration gas and perform a low and high range calibration on the NO ₂ sensor.
	6. The patient circuit setup is incorrect.	Ensure circuit is setup according to Section 3.
	7. Sample line blocked.	Confirm if NO ₂ high alarm occurs concurrently with "SAMPLE BLOCKED" message.
	8. The AeroNOx 2.0™ may have failed.	a. Contact International Biomedical Technical Support. b. Replace delivery system if in use.

Medium Priority Alarms		
Medium Priority Alarms	Possible Cause	Recommended Action
 <p>SAMPLE BLOCKED</p>	1. Water contaminates sample line or filter.	Replace filter or sample line.
	2. Sample line may be blocked or pinched.	a. Make sure sample line and outlet ports are not obstructed. b. Change sample line.
	3. Sample pump failure.	a. Make sure sample line and outlet ports are not obstructed. b. Restart unit, if alarm reoccurs replace sample pump.

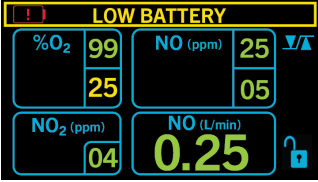
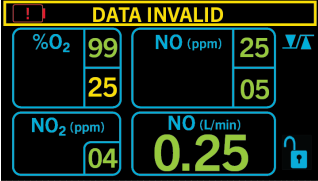
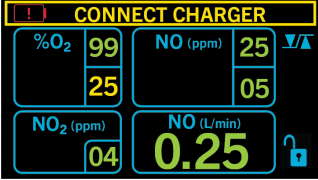
Medium Priority Alarms		
Medium Priority Alarms	Possible Cause	Recommended Action
 <p>O₂ High</p>	1. Alarm is set inappropriately	a. Make sure alarm is set appropriately for the O ₂ setting delivered on the ventilator.
	2. O ₂ calibration may have drifted.	a. Perform a low and high range calibration on the O ₂ sensor. b. Change the O ₂ sensor if the unit fails to calibrate. c. Contact International Biomedical Tech Support.
 <p>O₂ Low</p>	1. Alarm is set inappropriately	a. Make sure alarm is set appropriately for the O ₂ setting delivered on the ventilator.
	2. O ₂ calibration may have drifted.	a. Perform a low and high range calibration on the O ₂ sensor. b. Change the O ₂ sensor if the unit fails to calibrate. c. Contact International Biomedical Tech Support.
	3. O ₂ concentration on the ventilator was reduced.	Make sure O ₂ setting on the ventilator is correct for the O ₂ setting on the AeroNOx 2.0™.
	4. The O ₂ sensor may not be seated properly	Make sure sensor is seated and with O-rings and housing cover fully closed.

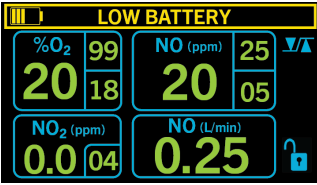
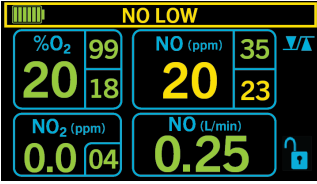
 <p>NO High</p>	<ol style="list-style-type: none"> 1. New installed NO sensors will give a high reading until fully biased (48-72 hours) and calibrated. 2. The NO high alarm is inappropriately set. 3. The NO calibration may have drifted. 4. Circuit setup is incorrect. 5. Out of date or wrong calibration gas used. 	<ol style="list-style-type: none"> a. After installation of NO sensor, perform a high and low calibration. b. Wait 48-72 hours and repeat high and low calibration. <p>Make sure the NO high alarm is set greater than measured value.</p> <p>Perform a low and high range calibration of NO sensor.</p> <p>Check circuit for correct setup.</p> <ol style="list-style-type: none"> a. Verify gas calibration date. b. Replace calibration gas and perform a low and high range calibration on the NO sensor.
   <p>Alternating: Low Battery Connect Charger Data Invalid</p>	<ol style="list-style-type: none"> 1. Battery voltage has dropped to a point where data is no longer accurate. 	<ol style="list-style-type: none"> a. Disconnect patient and manually ventilate with INOstat Bagger. See Section 3. b. Plug AeroNOx 2.0™ into AC outlet.

Low Priority Alarms		
Low Priority Alarms	Possible Cause	Recommended Action
 <p>Low Battery</p>	<ol style="list-style-type: none"> Battery is running low approximately 5 minutes until depletion. 	<ol style="list-style-type: none"> Connect to AC power source. If connected to AC powers ensure green charging light is on and cord is fully inserted into socket.
 <p>NO Low</p>	<ol style="list-style-type: none"> The patient gas sample line may be disconnected. 	Reconnect patient gas sample line.
	<ol style="list-style-type: none"> The NO low alarm may be inappropriately set. 	Make sure the set NO low value is above measured parameter.
	<ol style="list-style-type: none"> The NO calibration may have drifted. 	Perform a low and high range calibration on the sensor.
	<ol style="list-style-type: none"> The NO sensor may not be properly seated. 	Make sure the sensor gasket is fully seated and the housing cover is properly closed.
	<ol style="list-style-type: none"> Out of date or wrong calibration gas used. 	<ol style="list-style-type: none"> Verify gas calibration date. Replace calibration gas and perform a low and high range calibration on the NO sensor.

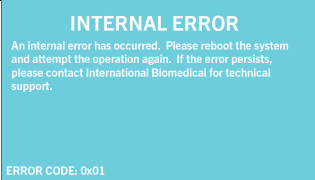
Other Messages		
Indicator	Cause	Recommended Action
	<p>Safety Shut Off system has been deactivated. See Section 4., ALARMS.</p>	<p>a. To reactivate push and hold Silence Alarm and Back buttons simultaneously.</p>
 <p>Battery Power Indicator</p>	<p>Device is running on battery</p>	<p>a. Connect to A/C power source when available. b. Make sure power cord is fully inserted into socket and green LED power light is illuminated.</p>
 <p>A/C Power Indicator</p>	<p>Device is running on A/C power and charging</p>	<p>a. N/A</p>
 <p>INTERNAL ERROR</p>	<p>Internal failure</p>	<p>Make sure internal battery is connected and charged.</p> <p>Otherwise, contact International Biomedical for service.</p>

6. CALIBRATION

6.1. Low Range (ZERO) Calibration (Daily)

The low range calibration of the AeroNOx 2.0™ uses room air to calibrate the NO, NO₂, and O₂ sensors at the same time. The system draws in room air from the sample port. This must also be done during the weekly high calibration.

Low Range Calibration	
<p>If unit is on, turn unit off and back on again using power button on front of AeroNOx 2.0™.</p>	
<p>During startup press and hold the “BACK” soft key to enter calibration mode. It will only be available for ~5 seconds.</p>	<div style="border: 1px solid black; padding: 5px;"> <p>Firmware Ver: V7RC7.1 0.0399 0 Build Date: 2016-04-11 0.0055 152 Display Ver: 2.12 0.4882 10</p>  <p style="text-align: center;">Hold  to Enter Calibration Mode</p> </div>
<p>Press “Zero Cal” soft key to enter low range calibration.</p> <p><u>NOTE:</u> “Zero” value for O₂ is 21%</p> <p>Unplug sample line or calibration circuit if connected. Allow the device to sample ambient air for a few minutes to clear out the sample path.</p>	

Low Range Calibration	
<p>Press and hold “Hold to ZERO” soft key until timer completes (~3 seconds). When zero cal is finished, it will read “DONE”.</p> <p>Monitor should indicate: NO - 0 ppm NO₂ - 0 ppm %O₂ - 21%</p>	

6.2. O₂ High Range Calibration (WEEKLY)

High range calibration requires a 100% O₂ user supplied gas source. Low Range calibration must be performed first.

O ₂ High Range Calibration	
<p>Enter Calibration Mode by holding “BACK” button on startup.</p>	
<p>Press “High Cal” soft key.</p>	

O₂ High Range Calibration

Connect calibration circuit (P/N 738-1850) to 100% O₂ gas source.

Set O₂ to ~ 1 L/Min.

NOTE: Check valve will dump excess flow if oversupply of O₂ is given.

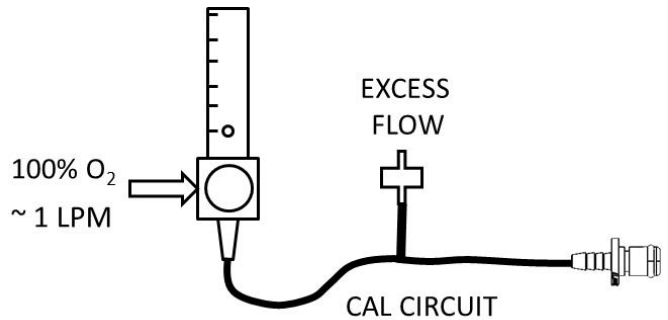

Connect sample line plug of calibration circuit into AeroNOx 2.0™ sample port.



Press "O₂" soft key.

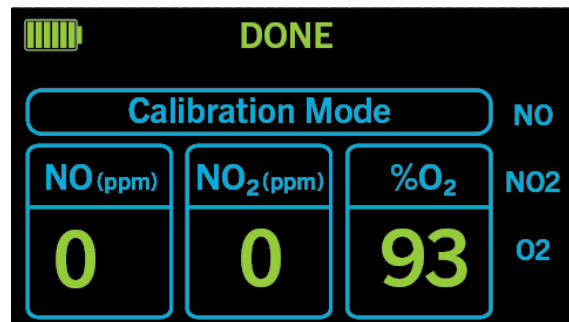

%O₂ becomes highlighted and displays current measured value. When display has stabilized after 2-4 minutes, use "UP AND DOWN" arrow keys to adjust reading to 100% O₂.

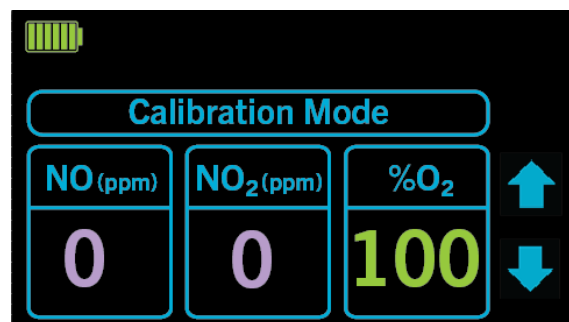

6.3. NO High Range Calibration (WEEKLY)

Perform low range calibration first.

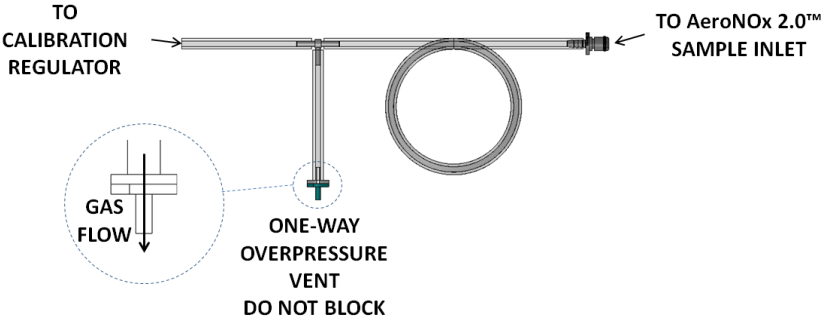
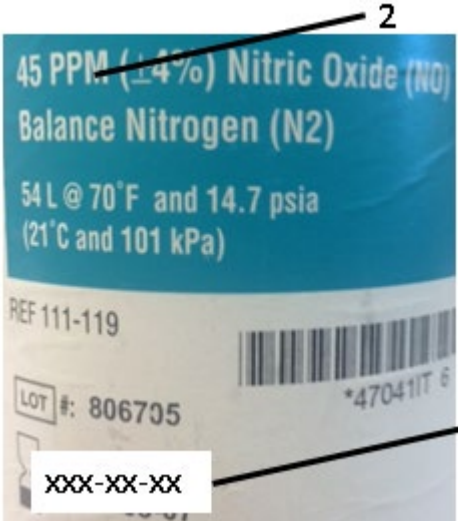
NO High Range Calibration	
<p>If O₂ high calibration was just completed, press the “BACK” button until gas selection screen is shown.</p> <p>Otherwise, enter Calibration Mode by holding “BACK” button on startup.</p>	
<p>Locate calibration circuit.</p> <p>NOTE: Same calibration circuit from O₂ may be used.</p>	
<p>Obtain NO Calibration gas and calibration regulator, confirm the following from the label:</p> <ol style="list-style-type: none"> 1. Exp. Date 2. Concentration 	

NO High Range Calibration

Connect calibration regulator to NO cal gas. Connect calibration circuit to calibration regulator.

1. Calibration regulator (731-9141)
2. Calibration Circuit (738-1850)

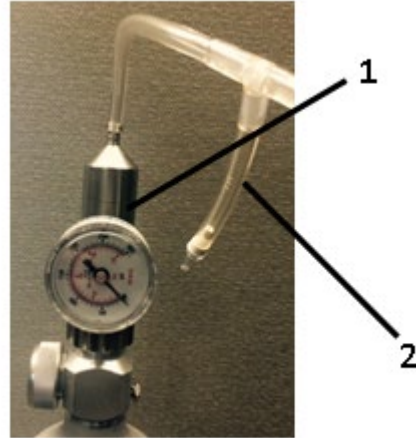

Press “NO” soft key.

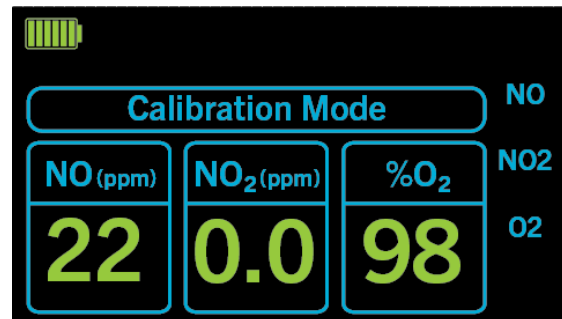

NO ppm becomes highlighted and displays current measured value.

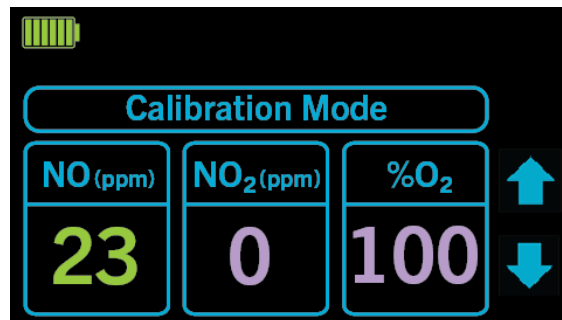

Turn cylinder on. (Replace cylinder if pressure is below 500 psi). Allow gas to vent for 10 seconds then attach calibration circuit to the AeroNOx 2.0™ sample inlet.



NO High Range Calibration

When NO display has stabilized after 2-4 minutes, use “**UP/DOWN**” arrow keys to adjust reading to concentration on label (i.e., 20 ppm).

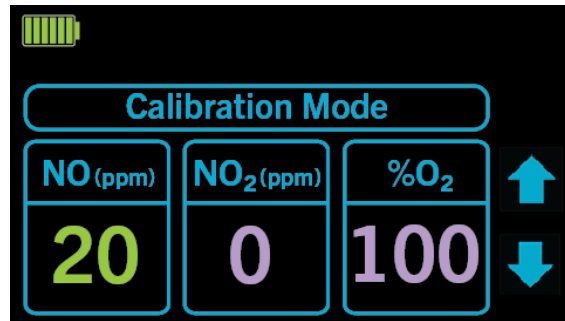

6.4. NO₂ High Range Calibration (WEEKLY)

Perform low range calibration first.

NO₂ High Range Calibration

If NO high calibration was just completed, press the “**BACK**” button until gas selection screen is shown.

Otherwise, enter Calibration Mode by holding “**BACK**” button on startup.

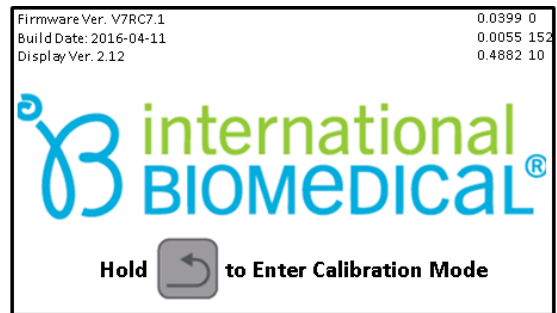

Locate calibration circuit.

NOTE: Same calibration circuit from O₂ and NO may be used.

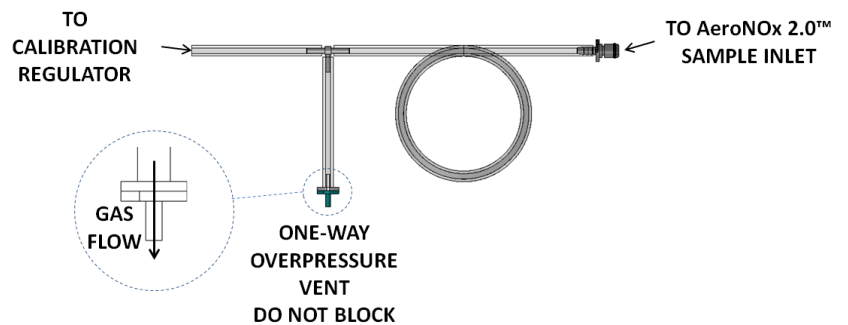

NO₂ High Range Calibration

Obtain NO₂ Calibration gas, confirm the following from the label:

1. Exp. Date
2. Concentration

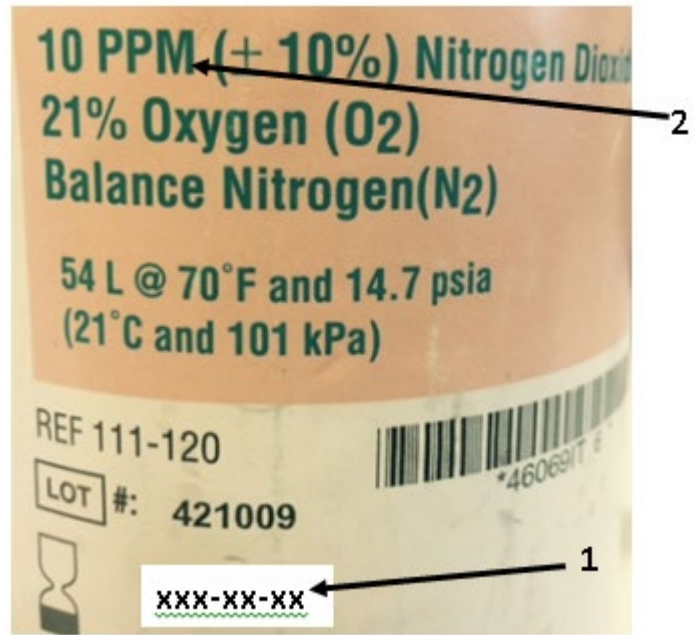

Connect calibration regulator to NO₂ cal gas. Connect calibration circuit to calibration regulator.

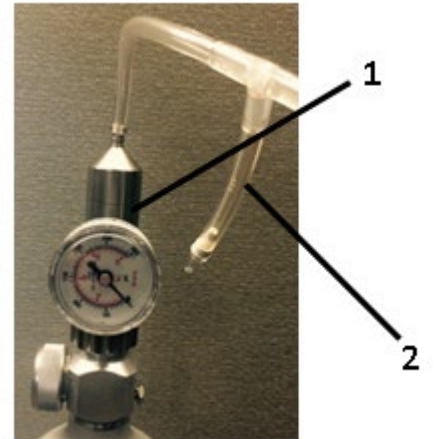

1. Calibration Regulator (731-9141)
2. Calibration Circuit (738-1850)

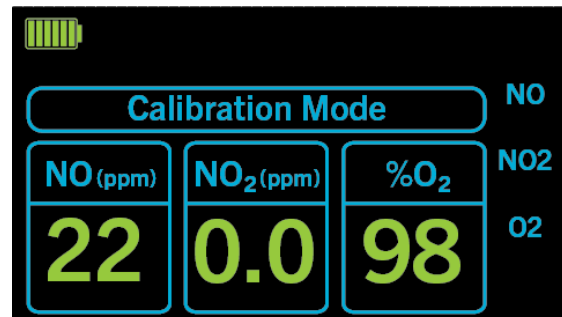

Press "NO₂" soft key.

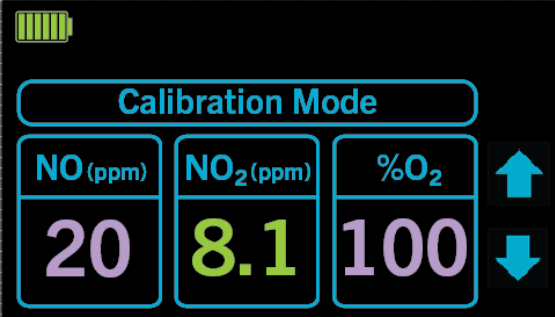

NO₂ High Range Calibration

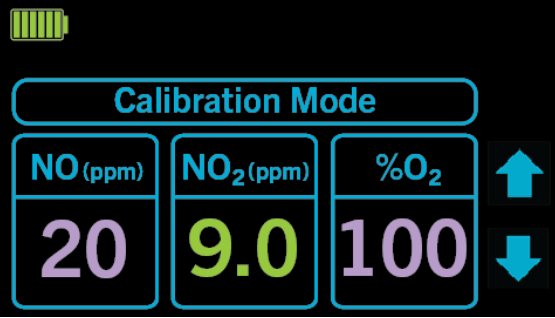
<p>NO₂ ppm becomes highlighted and displays current measured value.</p>	
<p>Turn cylinder on. (Replace cylinder if pressure is below 500 psi). Allow gas to vent for 10 seconds then attach calibration circuit to the AeroNOx 2.0™ sample inlet.</p>	
<p>When NO₂ display has stabilized after 2-4 minutes, use “UP/DOWN” arrow soft keys to adjust reading to concentration on label (i.e., 9.0 ppm).</p>	

The AeroNOx 2.0™ is calibrated and ready for use.

7. **MAINTENANCE**

7.1. User Maintenance Schedule

Frequency	Maintenance
Daily	Perform low range calibration.
Start of each patient	Perform pre-use check.
Between each patient	1. Disinfect unit. 2. Ensure unit is plugged into A/C power. 3. Replace single use items used.
Weekly	Perform high range calibration
Annually	Preventive Maintenance

7.2. Cleaning the AeroNOx 2.0™

- a. Disconnect external power before cleaning.
- b. Apply cleaning solution to a cloth and wipe down outer surface and cable.
- c. Use only the following cleaning agents.
- d. Allow unit to dry thoroughly before use. Immediate use after exposure to excessive cleaning agents such as Isopropyl Alcohol can affect sensor performance. Take particular care around the sample inlet.

Cleaning Agent	Active Ingredients
Soap/Water (Various)	Phenols Phospholipid surfactant
Cavicide or Cavi Wipes	Diisobutylphenoxyethoxethyl dimethyl benzyl ammonium chloride 0.07% Isopropyl alcohol 17.2% Inert ingredients 82.5%
Isopropyl Alcohol	Up to 100% Isopropyl Alcohol
Ethanol	Up to 100% Ethanol
Bacillol 30 or Bacillol 30 Wipes	Ethanol Propan-2-ol Propan-1-ol n-alkyl-aminopropyl-glycine

NOTE: Only applicable to International/EU Markets.

7.3. Preventive Maintenance

Schedule		
Description	Section	Maintenance Interval
NO, NO ₂ , and O ₂ sensor replacement	Section 7.	1 Year
Calibration of sample flow rate	Service Manual	1 Year
Calibration of NO delivery flow rate	Service Manual	1 Year
Battery replacement	Section 7.	1 Year (SLA) 2 Years (LiFePO ₄)
Inspection of Exterior	N/A	1 Year
Inspection of Power Input Connection	N/A	1 Year

All routine maintenance, repairs, and replacement of standard parts should be conducted according to procedures outlined in the Service Manual. For all clinical or technical issues not addressed in the manual, please contact International Biomedical directly at:

Call 1-512-873-0033
FAX: 1- 512-873-9090

CUSTOMER SERVICE

Should you need clinical or technical information, please feel free to contact International Biomedical. To help us to help you, please have the following information available:



- A complete description of the problem / observation
- Model #
- Serial #
- Your Institution address
- Your fax #

The above information is necessary to determine warranty status as well as to gather the information necessary for us to fill out a Return Merchandise Authorization (RMA) should you need to send anything back for repair. **Any equipment sent to International Biomedical without an RMA will not be accepted for delivery.** Do not ship any products to International Biomedical without first obtaining an RMA.

7.4. Return Merchandise Authorization

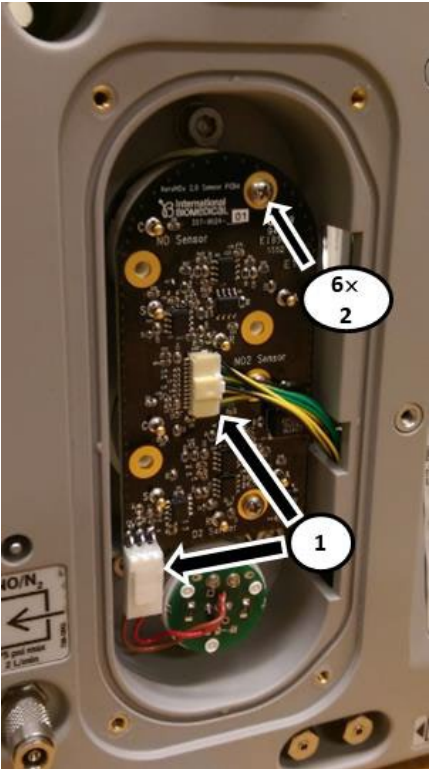

- To return AeroNOx 2.0™, contact customer service at International Biomedical.
- Pack device properly or contact customer service at International Biomedical for proper packaging.
- Disconnect battery.
- Pack AeroNOx 2.0™ as requested by customer service along with any requested accessories.
- Put RMA number on outside of packaging and send to location specified by customer service.

7.5. Replacing NO, NO₂, and O₂ Sensors

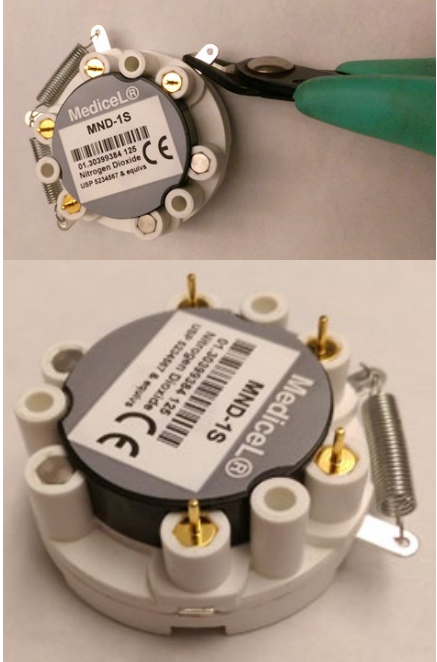
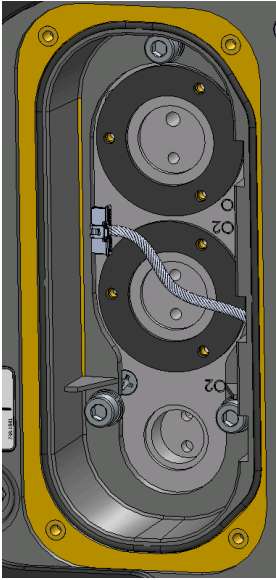

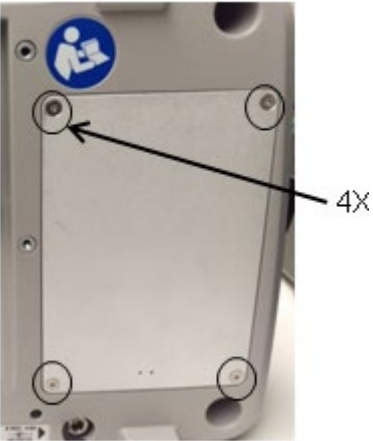

Sensor Replacement		
Description	Step	Illustration
<p>CAUTION: DISCONNECT BATTERY AND EXTERNAL POWER BEFORE SERVICE.</p>  <p>Remove rear sensor cover by loosening the 4 screws.</p>	<p>1</p>	
<ol style="list-style-type: none"> 1. Remove both connectors. 2. Remove six screws retaining circuit board. 3. Lift circuit board out and remove sensors. <p>NOTE: Sensors are socketed to the circuit board but may stick to manifold and/or gaskets. Keep both gaskets for re-use.</p> <ol style="list-style-type: none"> 4. O₂ sensor is removed by unscrewing body counterclockwise. Be careful not to cross thread. 	<p>2</p>	

Sensor Replacement		
Description	Step	Illustration
<p>1. Unpackage new sensors and remove shorting springs, wires, or bias board from sensor if present.</p> <p>2. Carefully clip tabs from sides of sensors to flush with sensor body.</p> <p>DO NOT CLIP VERTICAL PINS</p>	3	
<p>Re-use gaskets for NO and NO₂ sensors.</p> <p>Use new O-ring supplied with O₂ sensor (already attached).</p>	4	

7.6. Battery Replacement

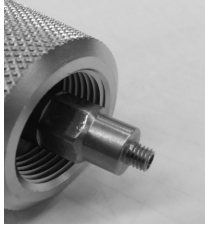
Description	Illustration
<p>The AeroNOx 2.0™ is shipped with an uninstalled rechargeable sealed lead acid (SLA) or Lithium Iron Phosphate (LiFePO₄) battery.</p> <p>To function properly, the device must have the battery installed.</p> <p>The battery does not require maintenance by anyone other than service personnel according the maintenance schedule.</p> <p>To install battery, remove four M3 screws securing battery compartment panel.</p>	
<p>Connect battery cable. Tuck mated connection into space below battery. Install battery in orientation shown.</p> <p>Replace cover.</p> <p>Reverse operations to remove battery.</p>	
<p>When operating on internal battery power, a battery icon is located on the screen.</p> <p>A fully charged battery will normally run the AeroNOx 2.0™ for five (5) hours in optimal conditions. When not turned on, the device continues to draw low power to maintain sensor readiness. In this state, it will last ~ 1 week on battery power alone. Therefore, it must be kept on AC power at all times.</p>	

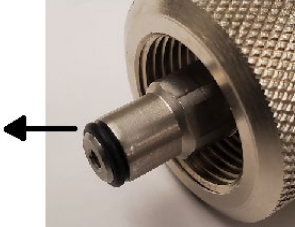
7.7. Replacing the Seal on the AeroNOx 2.0™ Regulators

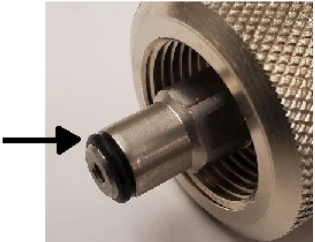
Replacing the Seal on Regulator	
Nipple type Seal	
Description	Illustration
<p>Remove worn-out tip on Delivery or Backup Regulators (CGA 626) by turning counterclockwise.</p> <p><i>NOTE:</i> <i>Threads are left-handed for CGA 625 Calibration Regulator with plastic nipple.</i></p>	
<p>Ensure threads are clean and undamaged.</p>	
<p>Install new tip hand tight. Do not use tools that may damage the sealing surface.</p> <p><i>NOTE:</i> <i>Threads are left-handed for CGA 625 Calibration Regulator with plastic nipple.</i></p>	
O-Ring type Seal	
Description	Illustration
<p>Remove worn-out O-Ring on Delivery or Backup Regulators.</p>	
<p>Ensure O-Ring groove is clean and undamaged.</p>	
<p>Install new O-ring. Do not use tools that may damage the sealing surface.</p>	

7.8. Parts and Accessories

Parts/Accessories	IB Part Number
Delivery Regulator with CGA 626 Fitting	731-9142
INostat Kit	731-9147
Calibration Regulator with CGA 625 Fitting	731-9141
NO Sensor, AeroNOx 2.0™ (4-Pin)	700-0002
NO ₂ Sensor, AeroNOx 2.0™ (4-Pin)	700-0003
Oxygen Sensor, AeroNOx	700-0600
O-Ring CGA 625/626, 5 Pack	731-0644
Seal Nipple (CGA 626), 5 Pack Delivery	731-9374
AeroNOx 2.0™ Calibration Circuit	738-1850
AeroNOx 2.0™ Test Circuit	738-1889
AeroNOx 2.0™ NO Supply Hose, 3'	738-1861
AeroNOx 2.0™ NO Supply Hose, 6'	738-1862
Dual Input NO Kit, AeroNOx 2.0™	738-1868
Power Supply Assembly, 9 V, Locking, AeroNOx 2.0™	293-0006
Power Cord, Incubator, NEMA 1-15P to IEC60320 C7, 6' (North America)	738-1916
Power Cord, Incubator, C18 to C7, 18", AeroNOx 2.0™	738-1914
Power Cord, Incubator, C18 to C7, 36", AeroNOx 2.0™	738-1913
Power Cord, Incubator, C18 to C7, 52", AeroNOx 2.0™	738-1915
Power Cord, CEE 7/16 to C7, 2m, AeroNOx 2.0™	738-1963
Back-Up Nitric Oxide Delivery Regulator	731-9143
AeroNOx "NO Worries"™ Connector Sample Pack	731-9373
Seal Nipple (CGA 625), 2 Pack Calibration	731-9375
AeroNOx 2.0™ Calibration Kit	731-0274
AeroNOx 2.0™ Sealed Lead Acid Battery (SLA)	888-0115*
AeroNOx 2.0™ Lithium Iron Phosphate Battery (LiFePO ₄)	888-0013*

*Replacement battery type must match battery being replaced.

Single Use Disposables	IB Part Number
AeroNOx 2.0™ Sample/Delivery Kit, Pack of 5	731-0276
AeroNOx 2.0™ TXP HFV Sample/Delivery Kit, Pack of 5	731-0277
INostat Baggers, 5 Pack	731-9919
AeroNOx 2.0™ Bagger, Pack of 5	731-0278

7.9. Mounting Options

Two means of mounting the AeroNOx 2.0™ to other devices are provided. Other than the accessories and external power supply specified in this manual, no other devices are intended to be mounted to the AeroNOx 2.0™.

7.9.1. **Dovetail**

The dovetail mount is used for quick attachment to a compatible receptacle. This mount does not have positive retention in all directions, so it is not acceptable for use during transport outside the hospital.

If the AeroNOx 2.0™ is mounted to a cart or other device using the Dovetail mount, the user is responsible for ensuring the safety and stability of the system.

7.9.2. **VESA 75mm**

A commonly available VESA compliant M4 × 75 mm square pattern is provided on the back of the device for more robust or permanent installations. The available pattern of M4 inserts is supported with a reinforced internal nut plate which is resistant to vibration and higher loads expected during transport. There is a wide variety of mounts for televisions, monitors, and other electronics that are compatible. The surface or device to which the AeroNOx 2.0™ is attached should be analyzed to ensure sufficient strength for the expected environment. Four M4 screws with lock washers and at least five threads of engagement are recommended. Exact length must be determined depending on the thickness of the mounting plate used.

7.10. Disposal

Disposable single-patient-use accessories and sensors should be discarded in accordance with institution procedures. The device contains a lead acid or LiFePO₄ battery and must be recycled or returned to International Biomedical for proper disposal at end of life. DO NOT discard in trash. The remainder of the device may be disposed of per your hospital's policy for non-hazardous materials.

8. WARRANTY

Subject to the *exceptions** and upon the *conditions** stated below, International Biomedical warrants that the products sold under this sales order shall be free from defects in workmanship and materials for **one year** after delivery of the products to the original Buyer by International Biomedical, and if any such products should prove to be defective within such one year period International Biomedical agrees, at its option, (i) to correct by repair or at International Biomedical's election, by replacement with equivalent product any such defective product, provided that investigation and factory inspection discloses that such defect developed under normal and proper use (ii) to refund the purchase price.

The *exceptions** and *conditions** mentioned above are as follows:

- a) Exchange, and/or factory repaired components are warranted for ninety (90) days from ship date, from factory.
- b) Upgraded parts are warranted for 6 (six) months from ship date from factory.
- c) Electrochemical sensors are warranted for 6 (six) months from ship date to the original buyer.
- d) Components or accessories manufactured by International Biomedical, which by their nature are not intended to and will not function for one year, are warranted only to give reasonable service: what constitutes reasonable shall be determined solely by International Biomedical. A complete list of such components and accessories is maintained at the factory.
- e) International Biomedical makes no warranty with respect to components or accessories not manufactured by it in the event of defect in any such component or accessory. International Biomedical will give reasonable assistance to the Buyer in obtaining from the respective manufacturer whatever adjustment is authorized by the manufacturer's own warranty.
- f) Any International Biomedical product claimed to be defective must, if required by International Biomedical, be returned to the factory, transportation charges prepaid, and will be returned to Buyer with transportation charges collect unless the product is found to be defective due to workmanship or materials, in which case International Biomedical will pay all transportation charges, subject to receipt of original shipping invoices. The customer will be responsible for duty, taxes, border charges, or claims resulting from but not limited to the improper processing of customs documents. Any damage incurred during transit from the Buyer to International Biomedical due to poor or insufficient packaging will be the responsibility of the Buyer.
- g) If the product is a disposable or the like, it is warranted only to conform to the quantity and content and for the period stated on the label at the time of delivery.
- h) International Biomedical may from time to time provide a special printed warranty with respect to a certain product, and where applicable, such warranty shall be deemed incorporated herein by reference.
- i) International Biomedical shall be released from all obligations under all warranties, either expressed or implied, if any product covered hereby is repaired or modified by persons other than its own authorized service personnel unless such repair by others is made with the written consent of International Biomedical.

IT IS EXPRESSLY AGREED THAT THE ABOVE WARRANTY SHALL BE IN LIEU OF ALL WARRANTIES OF FITNESS AND OF THE WARRANTY OF MERCHANTABILITY AND THAT INTERNATIONAL BIOMEDICAL SHALL HAVE NO LIABILITY FOR SPECIAL OR CONSEQUENTIAL DAMAGES OF ANY KIND OR FORM ANY CAUSE WHATSOEVER ARISING OUT OF THE MANUFACTURE, USE, INABILITY TO USE, SALE, HANDLING, REPAIR, MAINTENANCE, OR REPLACEMENT OF ANY OF THE PRODUCTS SOLD UNDER THIS SALES ORDER.

Representations and warranties made by any person, including dealers and representatives of International Biomedical, which are inconsistent or in conflict with the terms of this warranty, shall not be binding upon International Biomedical unless reduced to writing and approved by an expressly authorized officer of International Biomedical.

**International Biomedical
8206 Cross Park Drive
Austin, Texas 78754
USA**

**Telephone: 1-512-873-0033
FAX: 1-512-873-9090
E-Mail: sales@int-bio.com
Website: int-bio.com**

9. PRODUCT SPECIFICATIONS

9.1. Ventilator Compatibility

The AeroNOx 2.0™ has been validated with the following ventilators:

Conventional:

1. Bio-Med Devices MVP-10 (CMV/IMV Mode)
2. Bio-Med Devices CV2i+ (CMV/IMV Mode)
3. Accutronic Fabian/TV-1 Evolution (IPPV Mode)
4. HAMILTON-T1 (PCV Mode)
5. Bio-Med Devices TV-100 (IPPV Mode)

High Frequency:

1. Percussionaire TXP-2D (frequencies between 5 Hz (300 bpm) and 8.3 Hz (500 bpm) and amplitude less than 30 cmH₂O with mean airway pressures of 8-18 cmH₂O)

9.2. Measurement Range and Accuracy

Parameter	Measurement Range	Meter Resolution	Sensor Accuracy	Device ¹ Accuracy
NO	0-99 ppm	1 ppm	± 1 ppm	± 2 ppm
NO ₂	0-9 ppm	0.1 ppm	± 0.1 ppm	± 2 ppm
O ₂	18-100%	± 1% O ₂	± 2% O ₂	± 3% O ₂
NO/N ₂ Flow	0-2 L/min	0.01 L/min	± 0.045 L/min	± 0.1 L/min

9.3. Backup Delivery Regulator

Parameter	Specification
Inlet Pressure	500-2250 psi
Outlet Flowrate	0.25 L/Min Fixed flow of NO/N ₂
Cylinder Valve Connection	CGA 626

9.4. INOstat Bagger

Parameter	Specification
O ₂ Gas Flow	10 L/Min
NO Gas Flow	0.25 L/Min
Delivered NO	20 ppm
NO ₂ Generated	0.2 ppm Maximum 20 ppm NO Delivered
Reservoir Volume	0.5 L
Bagger Dimensions	Approximately 30 cm length
Tidal Volume	500 ml Max Tidal Volume
Breath Rate	Maximum 100 bpm at PIP 18 cmH ₂ O PEEP 5 cmH ₂ O. Maximum 50 bpm at PIP 40 cmH ₂ O PEEP 5 cmH ₂ O
I:E Ratio	Variable

¹ Device accuracy is affected by the ventilator that is attached.

9.5. AeroNOx 2.0™ Delivery Regulator

Parameter	Specification
Inlet Pressure	500-2250 psi
Outlet Pressure	45-75 psi
Cylinder Valve Connection	CGA 626

9.6. AeroNOx 2.0™ Physical Specifications

Parameter	Specification
Weight (device + protective cover only)	4.4 kg
W × D × H	33 cm × 14 cm × 25 cm
Precision Metering Valve	~12 turns to fully open
Service Life	8 years with preventative maintenance
Gas Supply	Recommend NO @ 800ppm Balance N ₂
Alarm Sound Pressure Level	High Alarm - 56dB Max @ 1m Medium Alarm - 54dB Max @ 1m

9.7. AeroNOx 2.0™ Environmental Specifications

	Operating	Transport/Storage	Transient
Temperature	0° C to 39° C	-40° C to 5° C 5° to 35° C up to 90% RH 35° C to 70° C vapor pressure up to 50hPa	-20° C to 50° C
Humidity	15-90% RH non-condensing	See above	15-90% RH non-condensing
Ambient Pressure	62-120 kPa	62-120 kPa	Not rated
Altitude	3657 m (12,000 ft.)	3657 m (12,000 ft.)	Not rated
Ingress Protection AeroNOx 2.0™ Power Supply	IP33 ² IP22 ³	IP33 ² IP22 ³	Not rated Not rated

² (Falling liquid spray 60° from vertical for 5 min and 2.5 mm object protection)

³ (Dripping water at 15° from vertical for 2.5 min, and 12.5 mm object protection)

9.8. AeroNOx 2.0™ Electrical Specifications

Parameter	Specification
Medical Rated A/C Supply	Meanwell GSM40B09-P2S
Input Fuse	2A Self-resetting
Classification	Class II, 2 × MOPP
AeroNOx 2.0™ Input Voltage	80 – 264 VAC, 47/63 Hz
Battery	Sealed lead acid, 6 V, 4.5 Ah battery provides standalone power for 5 hours. IB P/N 888-0115. 1 year life.
NOTE: Batteries are not interchangeable. Contact International Biomedical Customer Service.	LiFePO ₄ 6.4 V, 4.5 Ah battery provides standalone power for 5 hours. IB P/N 888-0013. > 2 year life.
Standards	<ol style="list-style-type: none"> 60601-1 (General Requirements for basic safety and essential performance) 60601-1-2 (Electromagnetic Compatibility) 60601-1-8 (Alarms) 60601-1-12 (EMS Environment)

9.9. Sensor Specifications

	NO	NO ₂	O ₂	Flow
Max Overload	1500 ppm	200 ppm	N/A	N/A
Linearity	Linear	Linear	< 3% error	N/A
Response Time (T ₉₀)	< 10 s	< 50 s	≤ 13 s	10 ms
Effect of Temp on Accuracy	N/A	N/A	N/A	Compensated 0 to 50° C

For further sensor details visit the datasheets in Section 10., APPENDIX.

9.10. EMC Compliance

The AeroNOx 2.0™ has been tested and found to comply with limits for electromagnetic interference and susceptibility as defined by IEC60601-1-2. However, this equipment may radiate radio frequency (RF) energy and may cause harmful interference to other devices. The AeroNOx 2.0™ is intended for use in an electromagnetic environment in which radiated RF disturbances are controlled. The customer or the user of the AeroNOx 2.0™ can help prevent electromagnetic interference by operating the device in the environments and with the minimum separation distances specified below. Additionally, periodic maintenance as specified by International Biomedical will allow the device to continue to provide basic safety and essential performance.

GUIDANCE AND MANUFACTURER'S DECLARATION - EMISSIONS

The AeroNOx 2.0™ is intended for use in the electromagnetic environment specified below. The customer or user of the AeroNOx 2.0™ should ensure that it is used in such an environment.		
EMISSIONS TEST	COMPLIANCE	ELECTROMAGNETIC ENVIRONMENT - GUIDANCE
RF Emissions CISPR 11	Group 1	The AeroNOx 2.0™ does not use RF energy for its internal function. Therefore, its RF emissions are very low and are not likely to cause any interference in nearby electronic equipment.
Conducted Emissions CISPR 11	Class B	The AeroNOx 2.0™ is suitable for use in all establishments, including domestic, and those directly connected to the public low-voltage power supply network that supplies buildings used for domestic purposes.
Harmonics IEC 61000-3-2	Class A	
Flicker IEC 61000-3-3	Complies	
RTCA/DO-160F Section 21	Category M	Maximum level of conducted RF interface-Power line
RTCA/DO-160F Section 21	Category M	Maximum level of radiated RF interface

GUIDANCE AND MANUFACTURER'S DECLARATION - IMMUNITY

The AeroNOx 2.0™ is intended for use in the electromagnetic environment specified below. The customer or user of the AeroNOx 2.0™ should ensure that it is used in such an environment.			
IMMUNITY TEST	IEC 60601 TEST LEVEL	COMPLIANCE LEVEL	ELECTROMAGNETIC ENVIRONMENT - GUIDANCE
ESD IEC 61000-4-2	± 8 kV Contact ± 2/4/8/15 kV Air	± 8 kV Contact ± 2/4/8/15 kV Air	Floors should be wood, concrete, or ceramic tile. If floors are synthetic, the r/h should be at least 30%.
Surge IEC 61000-4-5	± 0.5/1 kV Differential ± 0.5/1/2 kV Common	± 0.5/1 kV Differential ± 0.5/1/2 kV Common	Mains power quality should be that of a typical commercial or hospital environment.
Power Frequency 50/60 Hz Magnetic Field IEC 61000-4-8	30 A/m	30 A/m	Power Frequency magnetic fields should be that of a typical commercial or hospital environment.

GUIDANCE AND MANUFACTURER'S DECLARATION - IMMUNITY

The AeroNOx 2.0™ is intended for use in the electromagnetic environment specified below. The customer or user of the AeroNOx 2.0™ should ensure that it is used in such an environment.

IMMUNITY TEST	IEC 60601 TEST LEVEL	COMPLIANCE LEVEL	ELECTROMAGNETIC ENVIRONMENT - GUIDANCE
<p>Conducted RF IEC 61000-4-6</p>	<p>3 Vrms 150 kHz to 80 MHz (AC/DC)</p> <p>6 Vrms (in ISM Bands between 150kHz and 80MHz)</p>	<p>3 Vrms 150 kHz to 80 MHz (AC/DC)</p> <p>6 Vrms (in ISM Bands between 150kHz and 80MHz)</p>	<p>Portable and mobile communications equipment should be separated from the AeroNOx 2.0™ by no less than the distances calculated/listed below:</p> $D = \frac{3.5}{V_1} \sqrt{P}$ $D = \frac{3.5}{E_1} \sqrt{P}$ <p>80 to 800 MHz</p> $D = \frac{7}{E_1} \sqrt{P}$ <p>800 MHz to 2.7 GHz</p> <p>Where P is the max power in watts and D is the recommended separation distance in meters.</p> <p>Field strengths from fixed transmitters, as determined by an electromagnetic site survey, should be less than the compliance levels (V1 and E1).</p> <p>Interference may occur in the vicinity of equipment containing a transmitter.</p>
<p>Radiated RF IEC 61000-4-3</p>	<p>10 V/m 80 MHz to 2.7 GHz</p>	<p>10 V/m 80 MHz to 2.7 GHz</p> <p>(V₁) Vrms</p> <p>(E₁) V/m</p>	<p>Where P is the max power in watts and D is the recommended separation distance in meters.</p> <p>Field strengths from fixed transmitters, as determined by an electromagnetic site survey, should be less than the compliance levels (V1 and E1).</p> <p>Interference may occur in the vicinity of equipment containing a transmitter.</p>
<p>Proximity fields from RF Wireless Communication Equipment IEC61000-4-3</p>	<p>See IEC60601-1-2:2014 8.10</p>	<p>See IEC60601-1-2:2014 8.10</p>	<p>This equipment should be placed no closer than 30cm from the nearest RF Wireless communication device.</p>

9.11. Essential Performance

COMPONENT	REQUIREMENT
<p style="text-align: center;">O₂ Alarm Limits</p>	<p>If the concentration is above or below the alarm limits, the condition must be detected and the operator informed through an alarm.</p>
<p style="text-align: center;">Power Supply</p>	<p>When the external Power supply falls outside of the limits for normal operation, the AeroNOx 2.0™ will switch to internal power. The operator will be informed of the power state.</p>
<p style="text-align: center;">Alarm</p>	<p>Alarm annunciation is critical to the device safety. Alarms are generated both audibly and visually. The alarm annunciator and display are critical elements of the device.</p>

10. APPENDIX

10.1. NO₂ Sensor Datasheet

Product Data Sheet

MND-1S MediceL[®]

Nitrogen Dioxide (NO₂) Gas Sensor
Part Number: AG010-H00

Key Features & Benefits:

- Capable of continuous measurement
- 4th electrode for additional temperature stability

Technical Specifications

MEASUREMENT

Operating Principle	4-electrode electrochemical
Measurement Range	0-50 ppm NO ₂
Maximum Overload	200 ppm
Output Signal	0.5 ± 0.1 µA/ppm
Response Time (T₉₀)	< 50 seconds
Typical Baseline Offset (clean air)	-0.75 to +0.75 ppm equivalent
Repeatability	2% of signal
Linearity	Linear

ELECTRICAL

Recommended Load Resistor	10 Ω
Bias Voltage	Not Required
Recommended Gain	0.8

MECHANICAL

Weight	21 g (nominal)
Housing Material	20% glass-filled polypropylene
Colour Coded Ring	Black
Orientation	Any

ENVIRONMENTAL

Typical Applications	Inhaled Nitric Oxide Therapy
Operating Temperature Range	-20°C to +50°C
Recommended Storage Temp	0°C to +20°C
Operating Pressure Range	800 - 1200 mBar
Differential Pressure Range	±100 mBar
Storage Temperature Range	800 - 1200 mBar
Operating Humidity Range	15% to 90% RH non-condensing

LIFETIME

Typical Long Term Output Drift	2% signal loss/month
Expected Operating Life	1 year
Standard Warranty	12 months from date of despatch

Product Dimensions

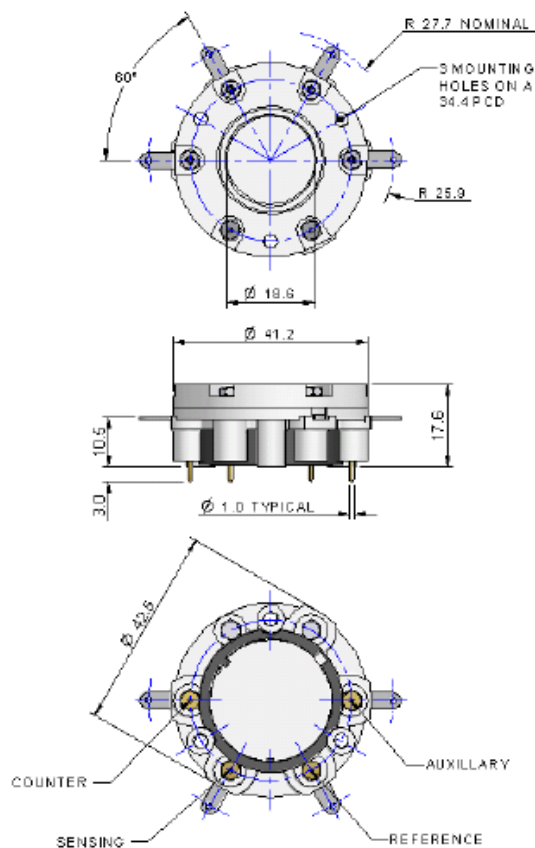

All dimensions in mm
All tolerances ±0.15 mm
unless otherwise stated

IMPORTANT NOTE:

Connection should be made via recommended mating parts only. Soldering to the sensor will damage it and invalidate the warranty.

All performance data is based on measurements made with cylinder gases using a flow rate of 100 mls/min. Conditions at 20°C, 50% RH and 1013 mBar, using City Technology recommended circuitry. For sensor performance data under other conditions, contact City Technology.

Product Data Sheet

Poisoning

CiTiceLs are designed for operation in a wide range of environments and harsh conditions, however it is important that exposure to high concentrations of solvent vapours is avoided, both during storage, fitting into instruments and operation.

When using sensors with printed circuit boards (PCBs), degreasing agents should be used before the sensor is fitted. Do not glue directly on or near the CiTiceL as the solvent may cause crazing of the plastic.

Cross Sensitivity Table

Whilst CiTiceLs are designed to be highly specific to the gas they are intended to measure, they will still respond to some degree to various gases. The table below is not exclusive and other gases not included in the table may still cause a sensor to react.

<u>Gas</u>	<u>Response</u>
Carbon Monoxide (CO)	None
Nitrous Oxide (N ₂ O)	None
Nitric Oxide (NO)	None
Desflurane	None
Isoflurane	None
Halothane	None

The cross-sensitivity values quoted are based on tests conducted on a small number of sensors. They are intended to indicate sensor response to gases other than the target gas. Sensors may behave differently with changes in ambient conditions and any batch may show significant variation from the values quoted.

N.B. Unaffected by operation in 100% oxygen

WARNING: By the nature of the technology used, any electrochemical or catalytic bead sensor can potentially fail to meet specification without warning. Although City Technology makes every effort to ensure the reliability of our products of this type, where life safety is a performance requirement of the product, and we recommend that all sensors and all instruments using these sensors are checked for response to gas before use.

Every effort has been made to ensure the accuracy of this document at the time of printing. In accordance with the company's policy of continued product improvement City Technology Limited reserves the right to make product changes without notice. No liability is accepted for any consequential losses, injury or damage resulting from the use of this document or from any omissions or errors herein. The data is given for guidance only. It does not constitute a specification or an offer for sale. The products are always subject to a programme of improvement and testing which may result in some changes in the characteristics quoted. As the products may be used by the client in circumstances beyond the knowledge and control of City Technology Limited, we cannot give any warranty as to the relevance of these particulars to an application. It is the clients' responsibility to carry out the necessary tests to determine the usefulness of the products and to ensure their safety of operation in a particular application.

Performance characteristics on this data sheet outline the performance of newly supplied sensors. Output signal can drift below the lower limit over time.

Doc. Ref.: mnd-1s.indd Iss 2 ECN I 2266
2nd December 2010

Page 2 of 2

www.citytech.com

City Technology Limited
City Technology Centre, Walton Road, Portsmouth, Hampshire PO6 1SZ UK
Tel +44 23 9232 5511 Fax +44 23 9238 6611



Product Data Sheet **MNO-1 & MNO-1B MediceLs[®]**

Nitric Oxide (NO) Gas Sensor

Part Numbers: AF0F4-H00 (standard) AF0F7-H00 (with Bias Board)

Key Features & Benefits:

- Capable of continuous measurement
- 4th electrode for additional temperature stability

Technical Specifications

MEASUREMENT

Operating Principle	4-electrode electrochemical
Measurement Range	0-100 ppm
Maximum Overload	1500 ppm
Output Signal	$0.25 \pm 0.05 \mu\text{A/ppm}$
Response Time (T_{90})	< 10 seconds
Typical Baseline Offset (clean air)	-1 to +1 ppm equivalent
Repeatability	2% of signal
Linearity	Linear

ELECTRICAL

Recommended Load Resistor	10 Ω
Bias Voltage	+300 mV
Recommended Gain	1.1

MECHANICAL

Weight	21 g (nominal)
Housing Material	20% glass-filled polypropylene
Colour Coded Ring	Orange
Orientation	Any

ENVIRONMENTAL

Typical Applications	Inhaled Nitric Oxide Therapy
Operating Temperature Range	-20°C to +50°C
Recommended Storage Temp	0°C to +20°C
Operating Pressure Range	800 - 1200 mBar
Differential Pressure Range	± 100 mBar
Storage Pressure Range	800 - 1200 mBar
Operating Humidity Range	15% to 90% RH non-condensing

LIFETIME

Long Term Output Drift	Depends on usage level
Expected Operating Life	1 year
Standard Warranty	12 months from date of despatch

Product Dimensions

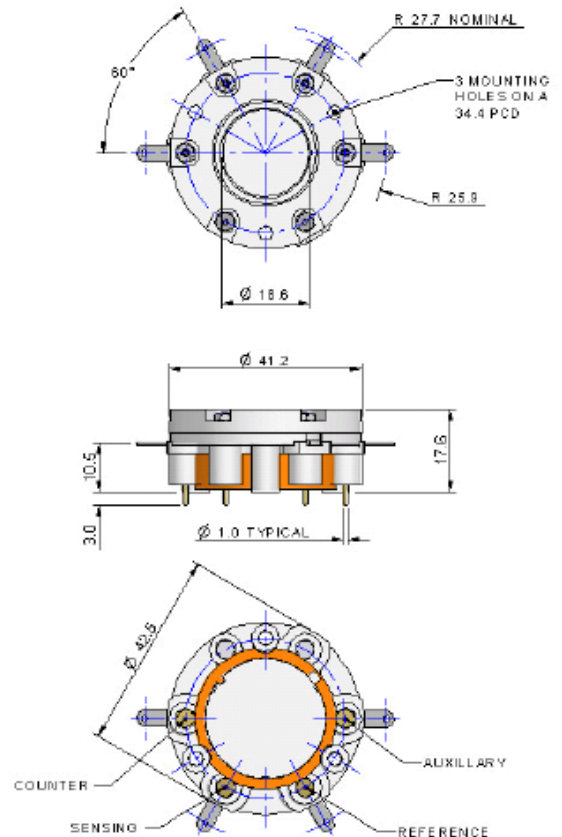

All dimensions in mm
All tolerances ± 0.15 mm
unless otherwise stated

IMPORTANT NOTE:

Connection should be made via recommended mating parts only. Soldering to the sensor will damage it and invalidate the warranty.

All performance data is based on measurements made with cylinder gases using a flow rate of 100 ml/min. Conditions at 20°C, 50% RH and 1013 mBar, using City Technology recommended circuitry. For sensor performance data under other conditions, contact City Technology.

Continuous Exposure

After continuous exposure to high concentrations of NO for several days the sensor may take some time to stabilise in fresh air before further use is advised. During this recovery period high baseline offsets may be seen. City Technology recommend 24 hours recovery period before reuse following exposures which exceed 4 days at levels of 80 ppm or above.

Poisoning

CiTiceLs are designed for operation in a wide range of environments and harsh conditions. However, it is important that exposure to high concentrations of solvent vapours is avoided, both during storage, fitting into instruments and operation.

When using sensors with printed circuit boards (PCBs), degreasing agents should be used before the sensor is fitted. Do not glue directly on or near the CiTiceL as the solvent may cause crazing of the plastic.

Cross Sensitivity Table

Whilst CiTiceLs are designed to be highly specific to the gas they are intended to measure, they will still respond to some degree to various gases. The table below is not exclusive and other gases not included in the table may still cause a sensor to react.

<u>Gas</u>	<u>Response</u>
Carbon Monoxide (CO)	None
Nitrous Oxide (N ₂ O)	None
Nitrogen Dioxide (NO ₂)	<25%
Desflurane	None
Isoflurane	None
Halothane	None

SAFETY NOTE

Although this product is not designed for use in life safety applications, if it is used in such applications it is a requirement that the function of the device is confirmed by exposure to target gas (bump check) before each use of the sensor and/or instrument, to ensure that the sensor and/or instrument in which it is used, are operating properly. Failure to carry out such tests may jeopardize the safety of people and property.

Every effort has been made to ensure the accuracy of this document at the time of printing. In accordance with the company's policy of continued product improvement City Technology Limited reserves the right to make product changes without notice. No liability is accepted for any consequential losses, injury or damage resulting from the use of this document or from any omissions or errors herein. The data is given for guidance only. It does not constitute a specification or an offer for sale. The products are always subject to a programme of improvement and testing which may result in some changes in the characteristics quoted. As the products may be used by the client in circumstances beyond the knowledge and control of City Technology Limited, we cannot give any warranty as to the relevance of these particulars to an application. It is the clients' responsibility to carry out the necessary tests to determine the usefulness of the products and to ensure their safety of operation in a particular application.

Performance characteristics on this data sheet outline the performance of newly supplied sensors. Output signal can drift below the lower limit over time.

10.3. Oxygen Sensor Datasheet

REV	DCO'S AFFECTING THIS DRAWING	DATE	APPROVED
A	INITIAL REL. #1209	4/5/99	D.L.
C	DCO # 3808 REVISED STORAGE TEMPERATURE	8/24/11	D.L.

ALL PRODUCT SPECIFICATIONS ARE APPLICABLE AT STANDARD CONDITIONS:
1013 MILLIBAR, 25° C DRY AIR.

- Output:
9.0 to 13.0 mV
- Operation:
Temperature: 0° – 40° C
Pressure: 600 – 1750 mBar
Relative Humidity: up to 100% RH
(Condensing atmosphere over several hours)
- Storage Temperature Range:
–20° to 50 °C
5° to 30°C Recommended
- Range of Measurement (Full Scale):
0 to 100% oxygen
- Zero Offset:
Less than or equal to 0.20 mV when exposed to 100% nitrogen for 5 minutes
- 90% Response Time:
Less than or equal to 13 seconds
- Linearity:
<3% error
- Stability:
Less than 1% of full scale over an 8 hour period between 20% and 100% Oxygen.
- Repeatability:
±1% volume oxygen @ 100% oxygen applied for 5 minutes
- Interference:
Less than 0.5% oxygen response to 80% Nitrous oxide
Less than 0.5% oxygen response to 7.5% Halothane
Less than 0.5% oxygen response to 7.5% Isoflurane
Less than 0.5% oxygen response to 7.5% Enflurane
Less than 0.5% oxygen response to 9% Sevoflurane
Less than 0.5% oxygen response to 20% Desflurane
Less than 0.5% oxygen response to 10% Carbon Dioxide
- Nominal Life:
> 1,000,000% oxygen hours under normal operating conditions
- Warm-up Time:
Less than 30 minutes after replacement of sensor
- Electrical Interface:
3 Pin, Female, Molex Connector

UNLESS OTHERWISE SPECIFIED DIMENSIONS ARE IN INCHES AND PER ANSI Y14.5-1982		maxtec® SALT LAKE CITY, UTAH 84108	
XX = ±.01	ANGLES = ±1°30'	SPECIFICATIONS	
.XXX = ±.002	PREP. D. LARSEN 3/26/98	MAX-14 OXYGEN SENSOR	
DRK. D. GOETZ 4/5/99	SIZE B	FSM NO. B	NUMBER R116P81
ENC. C. CINDRICH 8/10/11	SCALE NONE	REV. C	SHEET 1 OF 2

10.4. Competency Based Performance Check-off Tool

Introduction

In order to ensure patient safety, safe operation of clinical equipment is a necessity. Each employer is encouraged to have documented proof of employee competency in the operation of clinical equipment. For this purpose, International Biomedical has made available this competency based performance check-off. This clinical check-off is based on criterion-referenced performance. Employee performance is measured against pre-established standards of behavior. These behaviors are called critical elements. Critical elements are single, discrete, observable behaviors that are mandatory for meeting the standards of acceptability. Since competency in equipment operations is required, all critical elements must be performed as specified in order to pass. 100% accuracy is recommended for completion of the clinical performance check-off. Employees are strongly encouraged to review the Operating manual for the **AeroNOx 2.0™ Nitric Oxide Titration & Monitoring System** in order to familiarize themselves with the equipment functions, and to practice performing these functions independently as per the competency based check-off prior to the actual check-off by a clinician. During the actual check-off, the clinician is to merely observe the employee perform the required functions as per the check-off without offering assistance. As each function is performed, and if the criterion for performing the specified critical element is met, the clinician can tick off that item in the “criterion met” column. It may be necessary to provide teaching sessions or supervised practice sessions to staff prior to the clinical competency based check-off.

The following two competency based check-off tools are designed for:

- 1) *Routine (Weekly) AeroNOx 2.0™ Calibration*
- 2) *AeroNOx 2.0™ bedside or portable NO titration & analysis with a portable ventilator.*

AeroNOx 2.0™

1) Routine (Weekly) AeroNOx 2.0™ Calibration

COMPETENCY BASED PERFORMANCE CHECK-OFF #1 of 2

Employee Name:
Date of Check-Off:
Supervised by:

LOW CALIBRATE O₂, NO, & NO₂ SENSORS	Check
1. Turn Power on and hold BACK button to enter calibration.	
2. Disconnect Sample Line if present and allow device to sample room air for 1-2 minutes.	
3. Enter zero calibration mode by pressing ZERO CAL button. Press and hold the Hold to Zero button until the timer completes and DONE appears.	
4. Verify that %O ₂ = 21%, NO=0, and NO ₂ =0	
5. Exit Zero Cal by pressing BACK button	
HIGH CALIBRATE NO SENSOR	
6. Connect tube end of calibration circuit to calibrated NO source. <i>(Use only IB P/N 738-1850)</i>	
7. Connect the quick disconnect end of calibration circuit to the sample inlet of the AeroNOx 2.0™.	
8. Run NO through the cal. circuit @ approximately 0.5 LPM.	
9. Allow the NO reading to stabilize for 2 - 4 minutes.	
10. Enter high calibration mode by pressing HIGH CAL button.	
11. Select NO by pressing the corresponding button.	
12. Press UP/DOWN buttons until display matches corresponding NO bottle calibration (e.g., 80 ppm)	
13. Exit NO by hitting BACK button	
HIGH CALIBRATE NO₂ SENSOR	
14. Connect tube end of calibration circuit to calibrated NO ₂ source.	
15. Run NO ₂ through the cal. circuit @ approximately 0.5 LPM.	
16. Allow the NO ₂ reading to stabilize for 2 - 4 minutes.	
17. Select NO₂ by pressing the corresponding button.	
18. Press UP/DOWN buttons until display matches corresponding NO ₂ bottle calibration (e.g., 8.9 ppm)	
19. Exit NO ₂ by hitting BACK button	
HIGH CALIBRATE O₂ SENSOR	
20. Connect tube end of calibration circuit to wall 100% O ₂ source.	
21. Run wall O ₂ through the cal. circuit @ approximately 0.5 LPM.	
22. Allow the O ₂ reading to stabilize for 2 - 4 minutes.	
23. Select O₂ by pressing the corresponding button.	
24. Press UP/DOWN buttons until display reads 100% O ₂ .	
25. Exit O ₂ by hitting BACK button	
PURGE SENSORS	
26. Disconnect the calibration circuit and allow room air to be sampled into the AeroNOx 2.0™ until the NO and NO ₂ displays return to zero and the Oxygen sensor reads 21%. This will flush out any calibration gas remaining in the AeroNOx 2.0™ sampling circuit after calibration. This step will help ensure the longevity of the AeroNOx 2.0™ sensors.	
READY TO GO	
The AeroNOx 2.0™ is calibrated and ready for use.	Done

NAME: _____, employee # _____ has successfully completed the AeroNOx 2.0™ Calibration competency.

Date: _____ **Signature:** _____

2) AeroNOx 2.0™ Set-Up

COMPETENCY BASED PERFORMANCE CHECK-OFF #2 of 2

Employee Name:
Date of Check-Off:
Supervised by:

CRITICAL ELEMENTS	Check
1. Completed Calibration check off	
2. AeroNOx 2.0™ SET-UP: TRANSPORT or BEDSIDE Attach regulators to 800 ppm NO tanks	
3. SOURCE GAS: Attach high pressure quick connect from regulator(s) to AeroNOx 2.0™.	
4. DELIVERY: Attach delivery tubing from kit (P/N 738-1853) from AeroNOx 2.0™ to pt. circuit at least 30 - 40 cm upstream from the sampling site.	
5. SAMPLING: Attach sample line from kit (P/N 738-1853) from AeroNOx 2.0™ to inspiratory limb / bagger near patient connection.	
6. Double check [NO] of the cylinder & record = ____ ppm	
7. Double check NO tank pressure = ____ psig	
8. Calculate initial NO flow to achieve the desired [NO] (see Section 5.).	
9. Ventilator flow / gas flow = LPM	
10. Tank [NO] = _____ ppm	
11. Desired [NO] = _____ ppm	
12. Calculated Initial NO flow = _____ LPM	
13. Calculate maximal FiO ₂ (see Section 5.). Maximum FiO₂ = _____	
14. Perform flush procedure.	
15. Set NO flow @ the initial flow rate you calculated (# 12).	
16. After readings stabilize, record the following from the AeroNOx 2.0™ <ul style="list-style-type: none"> • Record [NO] _____ ppm • Record [NO₂] _____ ppm • Record % O₂ _____ 	
17. Calculate the cylinder NO duration in hours & minutes (see Section 5.). This _____ L tank of NO gas @ _____ psig will last _____ Hrs. _____ Min @ _____ LPM.	

NAME: _____, employee # _____ has successfully completed the AeroNOx 2.0™ Set-Up competency.

Date: _____ **Signature:** _____